

FW-500

FW-500



HOT & COLD WATER PURIFIER PRODUCT MANUAL

HOT & COLD WATER PURIFIER PRODUCT MANUAL



High Efficiency Compressor Cooling

Overflow Prevention Device

Unique And Stylish Design

Hot Water Safety Function

Stainless Steel Water Tanks

Various Color Options

Contents	Page
Piping Installation/Dos and Don'ts	1-2
Operation and Overview	3-4
Specifications	5
Water Filter Diagram	6
Cleaning	7
Hot Water Reset	8
Filter Replacement	9
Leak Detector	10

Please read the instructions completely before using this product.

Intended for water pressure between 25-60 psi.

If water pressure is more than 60 psi, please use a water pressure regulator.

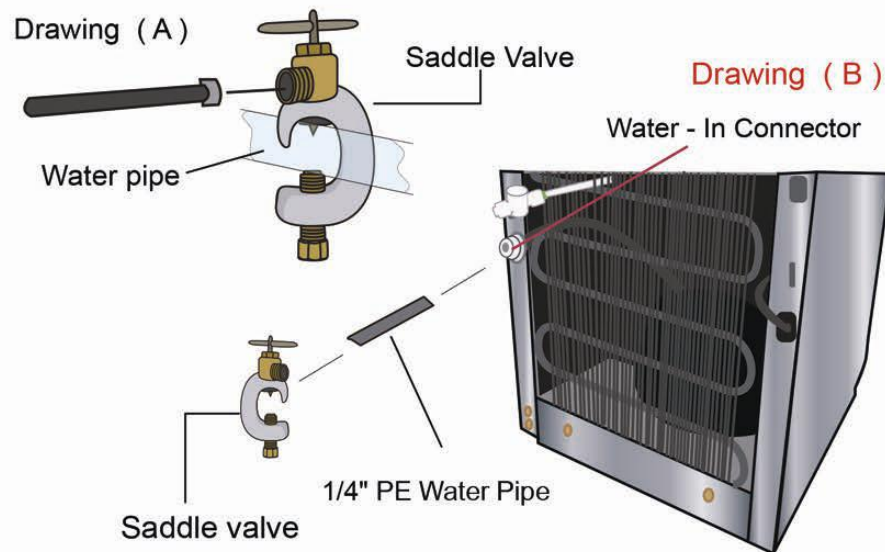

1. Shut off the main water supply or local water supply to the water pipe being tapped.
2. Insert rubber washer on underside of top saddle clamp.
3. Insert one bolt through the top and bottom clamps and turn it a couple of times.
4. Place the top clamp on the nearest cold water supply pipe, then rotate the bottom clamp under the water supply line. Insert the second bolt and evenly tighten both bolts on the saddle clamps.
5. Install the compression nut and plastic compression sleeve onto tubing. When using polyethylene tubing, use the brass insert to reinforce the tube wall.
6. Make sure the tubing is placed completely into the valve and tighten the compression nut. Tighten the nut by hand until it begins to bite. Using a crescent wrench, tighten the nut about 1/2 more turn.
7. Next, turn the valve handle clockwise slowly as far as possible. This will fully open the needle valve and allow the piercing tip to tap into the copper or brass water supply line.
8. Turn valve to 'OFF' position.
9. Turn on water supply and check for leaks.
10. To start the flow of water with the saddle valve, turn handle on the saddle valve fully counter-clockwise.

Install the product half an inch from the wall.

The power plug should be disconnected when changing filters.

Do not use thinner, benzene or wax for cleaning, and keep the product away from any volatile agents.

Install the product on a flat and firm surface.

Do not hit or kick your water system.

Do not tilt the product over 45° while moving, and do not operate while the product is tilted over 15°

Do not open or try to repair without help.

Wait for 30 minutes after moving your water cooler, before plugging it in to an electrical outlet

Do not twist or snap the inlet hose.

Do not place the product where the temperature is below 40° F

OPERATION

Precautions during installation

1. Confirm your electrical outlet is 110V
2. Make sure to use an individual outlet for the appliance

Caution:

- * If the power cord is damaged, replace it immediately
- * Children should not use the appliance without supervision
- * If the water pressure exceeds 60 PSI, use a pressure reducing valve.

Procedure for Operation

1. Install pinch valve to water source (see page 1)
(Do not connect pinch valve or adapter to hot water source)
2. Connect water line by pushing tube in to inlet on the back of the unit
3. Turn on the water supply
4. Wait at least 5 minutes and then make sure there is water in both tanks
5. Plug in the appliance in to a 110V electrical outlet
6. Turn on both the Hot and Cold switches, located on the back of the machine
(Do not turn on the hot water switch before making sure there is water in the tank)
7. Wait up to 50 minutes for cold water to cool and 20 minutes for hot water to heat
8. If unit will not be used for a long period of time, drain the unit using the drain cap located in the back of the unit and unplug it.

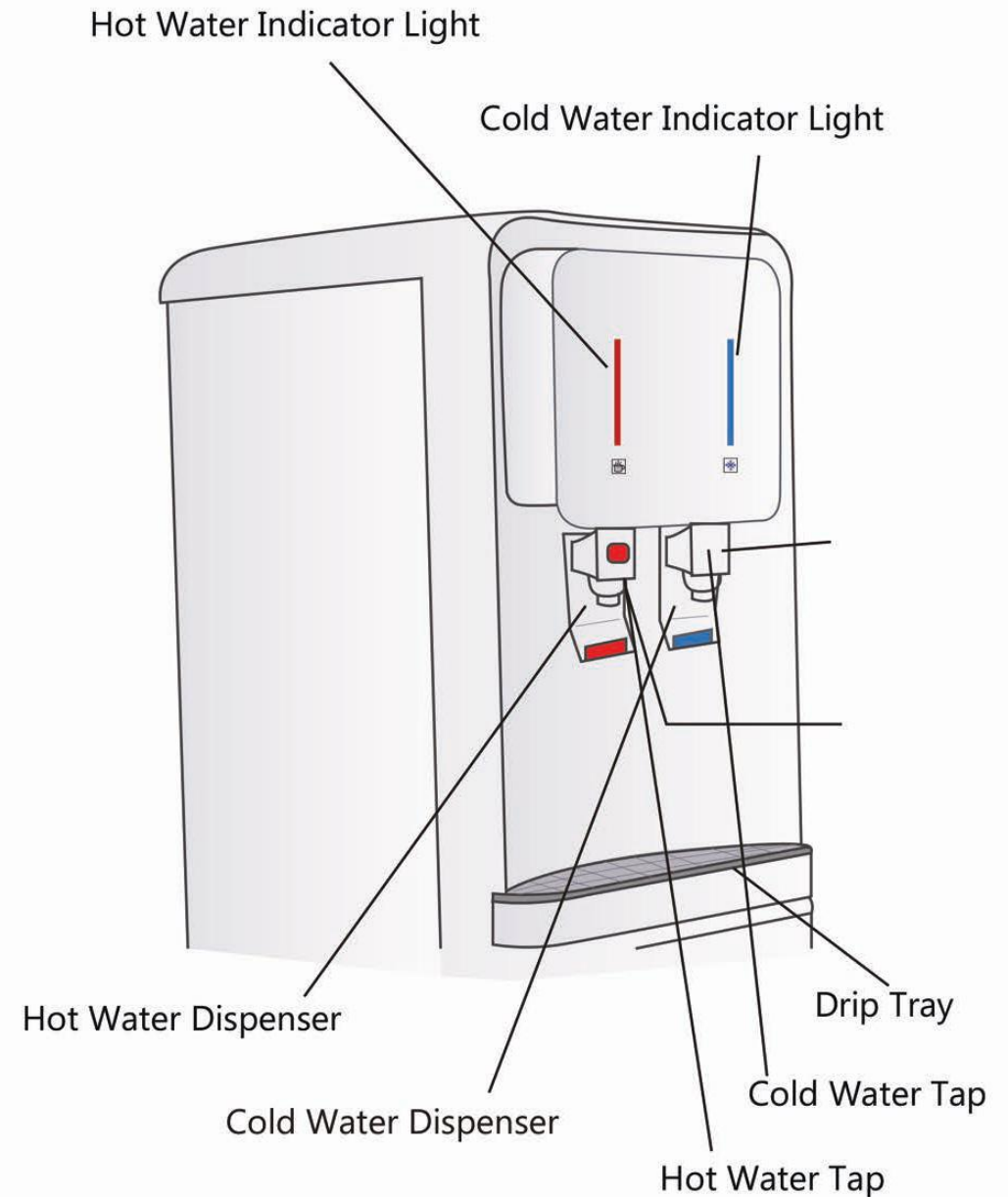

PRODUCT SPECIFICATION

WATER FLOW DIAGRAM

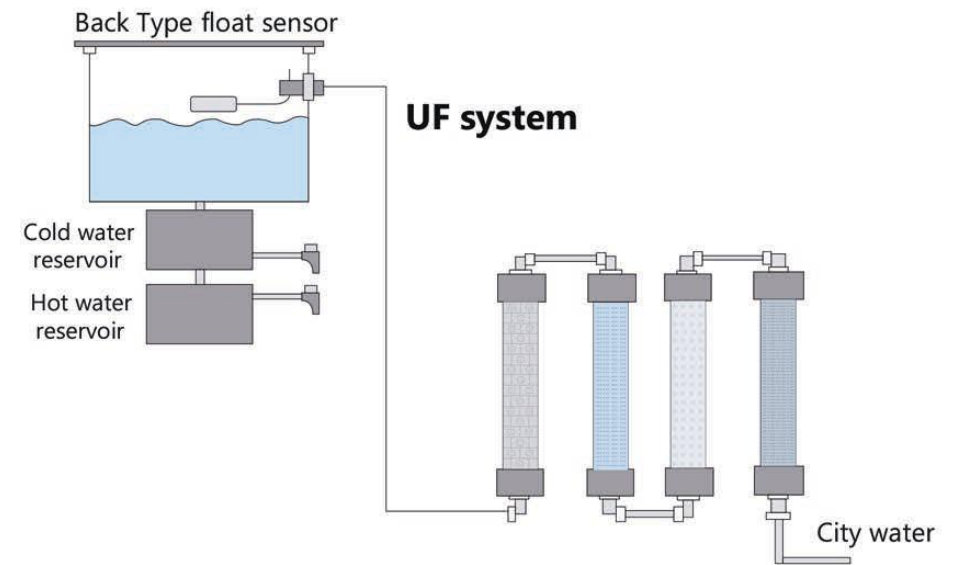
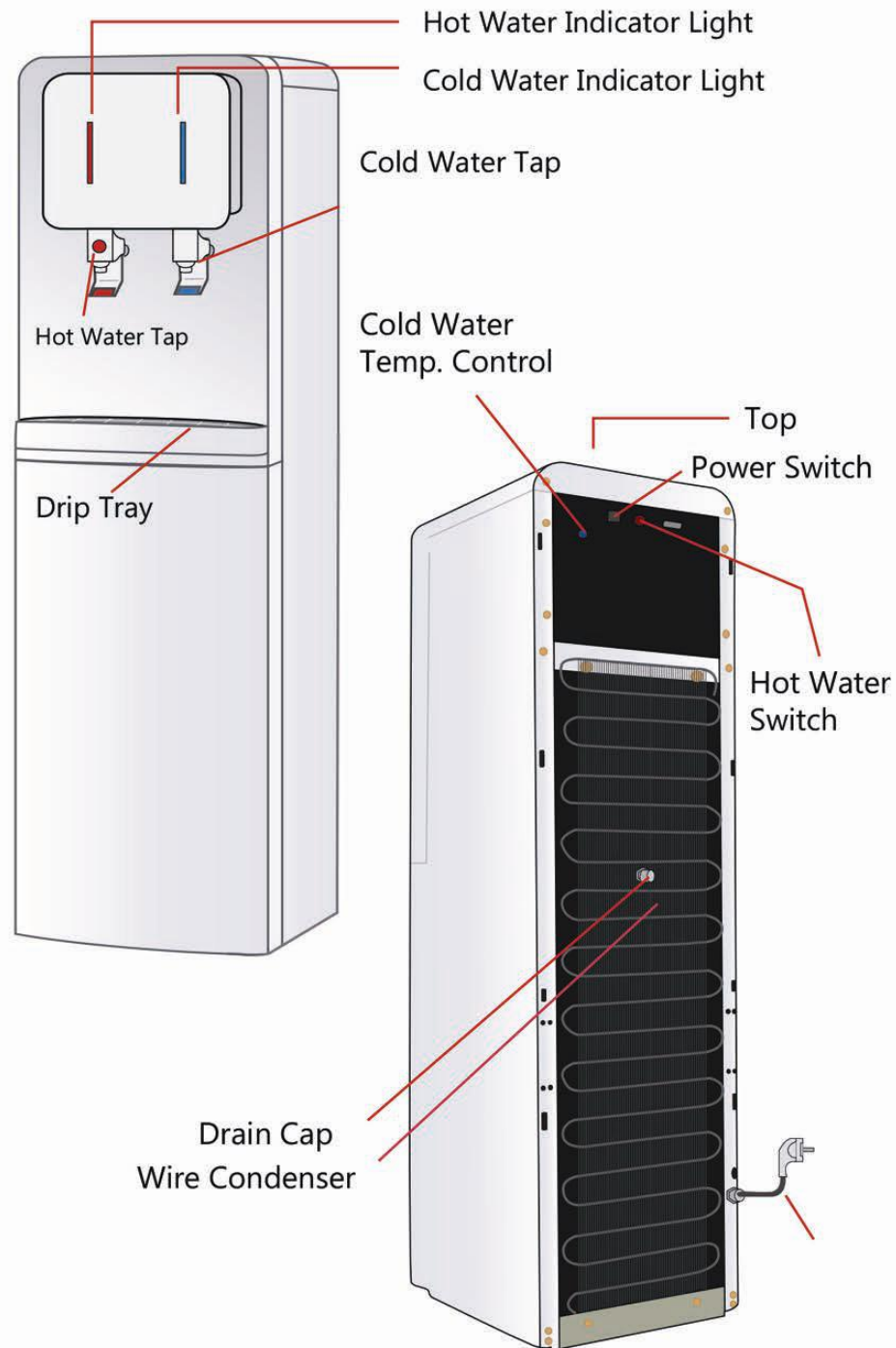

Stage 1 - The Sediment Filter maximizes the effect of water purification by eliminating rust, sand, silt, and pipe turbidity that is found in water supplies across the globe.

Stage 2 - This filter uses granulated activated carbon media from the Kuraray Carbon Company, tested and certified by the NSF. It removes chlorine, THM's, Benzene, Pesticides, Insecticides, and other contaminants that may be present in municipal water supplies.

Stage 3 - The Ultra Filtration Membrane filters water down to .002 microns, and is highly effective at removing bacteria, organic chemicals, and other water borne microorganisms.

Stage 4 - This filter utilizes proprietary carbon block technology to ensure that 99% of all chlorine, lead, and microbial cysts have been removed. It also provides a "polishing" effect, giving the water a crisp and delicious taste.

CLEANING

1. Turn off all switches located at the top rear of the unit.
2. Close the water intake valve.
3. Unplug the power cord.
4. Completely drain water from the unit.
Caution: Water may be HOT!
5. Unscrew the back two screws indicated below, and remove the top plastic cover.

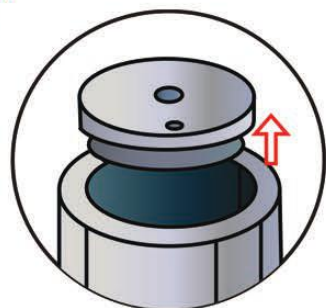
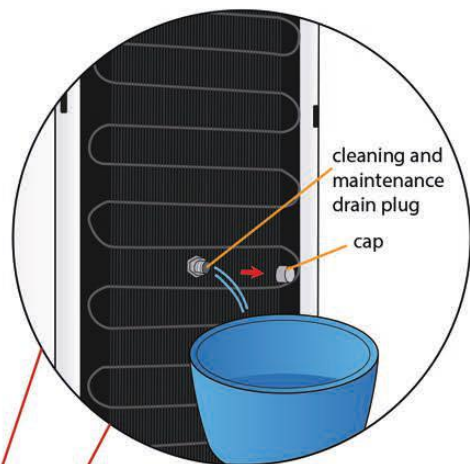

6. Under the plastic cover, you'll locate the cooling tank as illustrated above.
7. Remove the top cover of the cooling tank, as illustrated above.
8. Gently yet thoroughly wipe out the inside of the cooling tank with a clean cloth. Do not use any soap or other detergent.
9. Secure the top cover of the cooling tank, back in place.
10. Place the plastic cover back in place, and screw in the 2 screws.

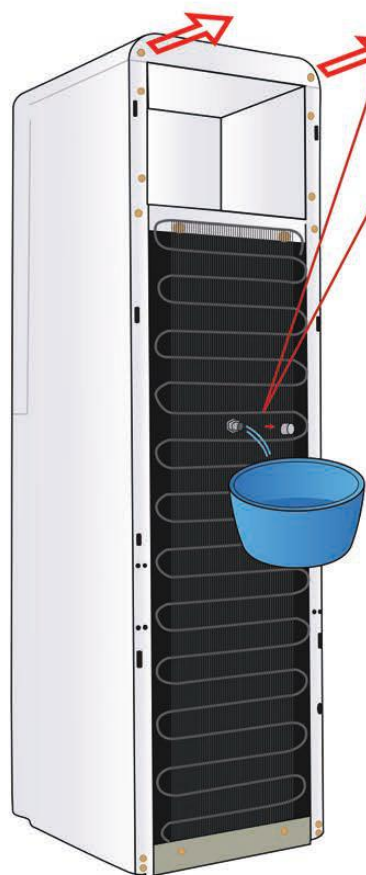

WATER RESET

If the HOT WATER POWER was turned on before completing the steps on page 3, it is likely the hot water safety feature has been triggered, and the hot water heating is disabled.

To reset the Hot Water please complete the following steps:

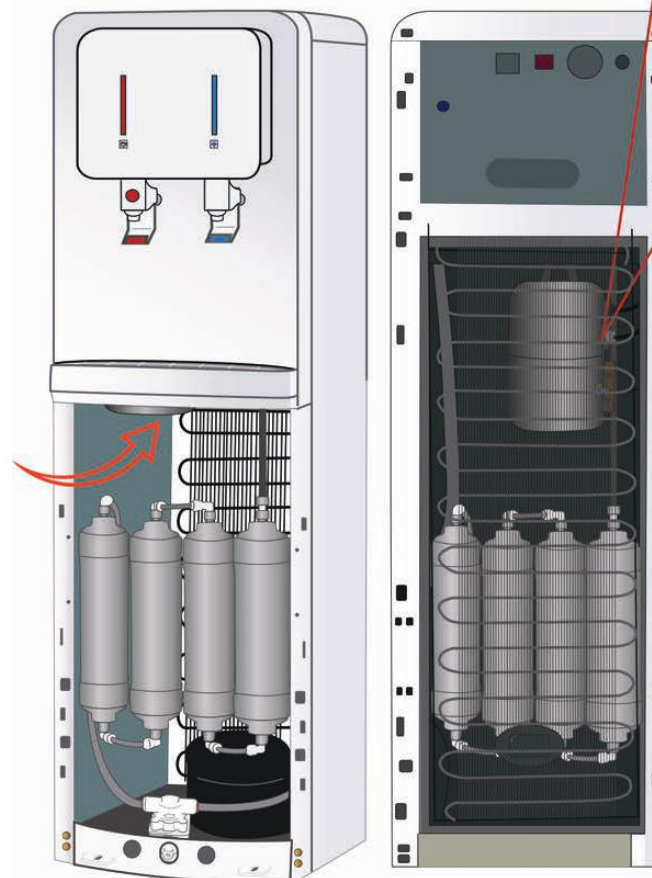
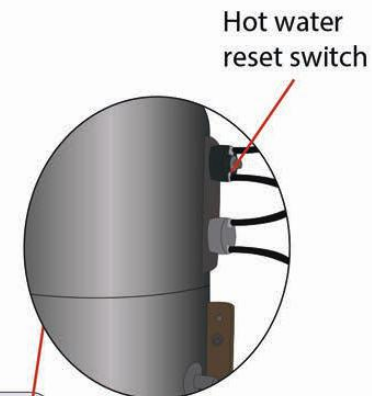

- a.) Please disconnect the electricity, and make sure all power switches are OFF
- b.) Locate the "Hot Water Reset Switch" by looking at the back of the unit through the cooling grate as pictured to the left.
- c.) Remove the lower front panel as pictured to the left, and reach in and up with your hand to feel for the switch.
- d.) Press the Hot Water Reset Switch.
- e.) Place the lower front panel back on the unit.
- f.) Please follow the set-up steps on page 3, and ensure there is water in the hot tank before turning the power switches back on.

FILTER REPLACEMENT

LEAK DETECTOR

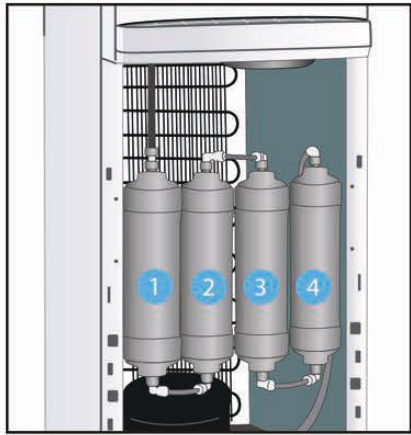

Your filters must be replaced at regular intervals to maintain optimal water quality and performance. (every 6 months)

1. Sediment Filter
2. Pre Carbon Filter
3. Ultra Filtration Membrane
4. Post Carbon Filter

- 1 TURN OFF ALL POWER SWITCHES AND WATER SUPPLIES
- 2 Pull Down & Off the front bottom panel.
- 3 Close the saddle valve to stop water flow through the filters.

- 4 Place a towel under the filters to catch water. The filters will have water in them which will run out when the filters are unlocked.
- 5 Push the collet towards the QC fitting to remove each filter from the tubes.
- 6 These filters are disposable, encapsulated filters. Remove and discard the entire filter body. Replacement filters are sold as a set:
- 7 Connect the new filters by pushing on the QC fittings.
- 8 Open saddle valve and let water flow through filters. When the cooler is full, empty out the water into a bucket. This will eliminate the first batch of water, which will be full of carbon dust.
- 9 After the cooler fills up again, turn on the power to the cold and hot tanks. Wait a few minutes to assure there are no leaks and close the front panel.

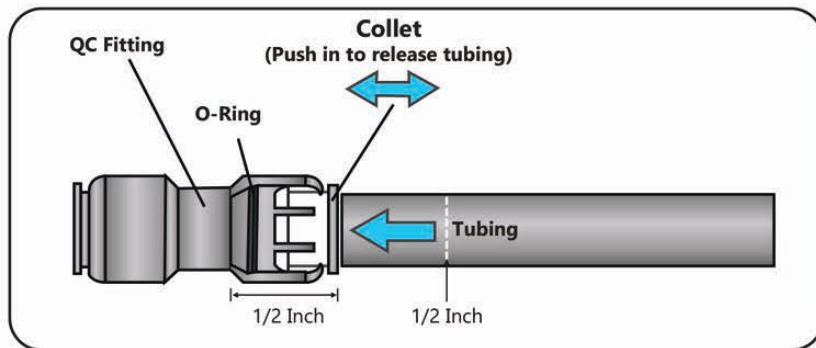

* To connect, insert the tubing 1/2 inch deep until it's sealed by O-ring and locked by spider teeth.

* To disconnect, remove blue clip, pull the tubing while pushing down the collet to release the spider.

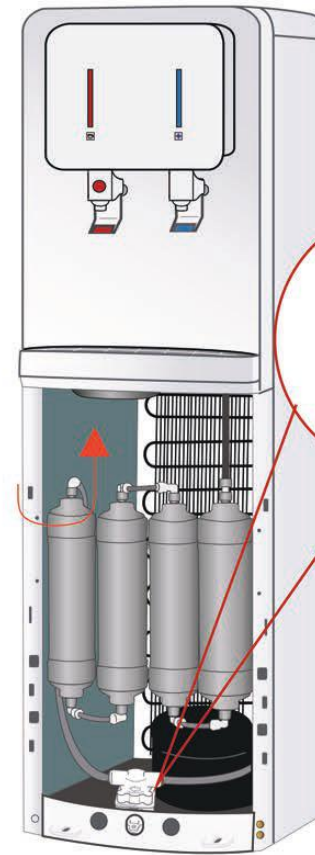

This machine is equipped with a leak protection device.

1. The water will cut off to the machine completely
2. Turn off the water feed and remove the front plate.
3. Wipe off the water from leak stop and machine with a dry cloth.
4. Locate the leak stop device, and pry open with a flat head screw driver or butter knife.
5. There will be a wet expanded paper circle, take this out and throw it away.
6. There will be a replacement paper circle stored in the side of the unit. Use this to replace the wet one, and close the leak stop unit.

