



CRYSTAL QUEST® Thunder Reverse Osmosis

Installation and Maintenance Instructions

MODELS
10,000, 15,000, & 20,000



CRYSTAL QUEST®
Copyright© 2017
All rights reserved.
Made in the USA



Introduction

Your Thunder commercial reverse osmosis system is a durable piece of equipment which, with proper care, will last for many years. This User's Manual outlines installation, operating, maintenance, and troubleshooting details vital to the sustained performance of your system.

The test results which are included with this User's Manual indicate your systems permeate (product) and rejection test results. Your system is designed to operate at a pressure of 150 psi, unless otherwise stated. The recovery set for your system is between 33%-50%.

If your system is altered at the site of operation or if the feed water conditions change, please contact your local dealer or distributor to determine the proper recovery for your application. **NOTE:** In order to maintain warranty, an operating log must be maintained. Copies must be sent to your local dealer or distributor for review.

NOTE: Prior to operating or servicing the Thunder commercial reverse osmosis system, this User's Manual must be read and fully understood. Keep it and other associated information for future reference and for new operators or qualified personnel near the system.

Safety

The Safety section of this User's Manual outlines the various safety headings used throughout this manual's text and are enhanced and defined below:

NOTE: Indicates statements that provide further information and clarification.

CAUTION: Indicates statements that are used to identify conditions or practices that could result in equipment or other property damage.

WARNING: Indicates statements that are used to identify conditions or practices that could result in injury or loss of life. **FAILURE TO FOLLOW WARNINGS COULD RESULT IN SERIOUS INJURY OR EVEN DEATH.**

Labeling

Do not under any circumstance; remove any Caution, Warning, or other descriptive label from the system.

System Specifications

Gallons Per Day	10000	15000	20000
Dimensions (approx.)	49" x 31 "x 54"	56.5" x 31 "x 54"	64" x 31 "x 54"
Weight (approx.)	385 lbs.	400 lbs.	415 lbs.
Recycle Line	Optional	Optional	Optional
Auto Flush	Optional	Optional	Optional
Element Size (in.)	4040 TFC HF-1	4040 TFC HF-1	4040 TFC HF-1
Elements (qty.)	6	8	10
MotorHP	3	3	5
Voltage	220 1 Phase	220 1 Phase	220 3 Phase
Hertz	60	60	60

Feed Connection	2"	2"	2"
Product Connection	1"	1"	1"
Waste Connection	1"	1"	1"
Minimum Feed (gpm)	14 @ 50% Recovery	21 @ 50% Recovery	30 @ 50% Recovery
Maximum Feed (gpm)	30	30	50

Feed Water & Operation Specifications

Nothing has a greater effect on a reverse osmosis system than the feed water quality. For lasting performance it is important to supply the system with the feed water quality shown below. It is also important to feed the system the required amount of feed water. **NOTE:** It is very important to meet the feed water requirements. Failure to do so will cause the membranes to foul and void the warranty.

Feed Water Specifications

Free Chlorine	<1 ppm	Manganese	<0.05 ppm
Total Dissolved Solids	<2000 ppm	Organics	<1 ppm
Turbidity (SDI)	<5	Temperature	40°F-105°F
pH	3-11	Silica	<1 ppm
Hardness	<15gpg	Iron	<2 ppm in Concentrate

The manufacturer has provided you with operation specifications. These specifications should be met in order to have the reverse osmosis system perform optimally. All operation specifications are based on the test conditions listed below.

Operation Specifications

Minimum Feed Pressure	35 psi	Minimum NaCl Rejection	96%
Nominal % Rejection	98.5%	Maximum Hardness	15gpg
Maximum TDS	2000 ppm	Operating Pressure	150 psi
pH Range	3-11	Maximum Temperature	110°F

Test Conditions: Permeate flow and salt rejection based on 550 TDS , 150 psi, 77°F (25°C), pH 7, and recovery as indicated. **NOTE:** Higher TDS and/or lower temperatures will reduce the system's production.

Rejection, Recovery, & Flow Rates

Thunder reverse osmosis systems are designed to produce purified water at the capacities indicated by the suffix in the system's name under the conditions listed above. For example, the Thunder 10000 produces 10000 gallons per day of purified water @ 77°F.

The amount of total dissolved solids (TDS) rejected by the membrane is expressed as a percentage. For example, a 99% rejection rate means that 99% of total dissolved solids do not pass through the membrane. To calculate the % rejection, use the following formula:

$$\% \text{ Rejection} = (\text{Feed TDS} - \text{Product TDS} / \text{Feed TDS}) \times 100$$

NOTE: All TDS figures must be expressed in the same units, usually parts per million (ppm) or milligrams per liter (mg/l).

Thunder commercial reverse osmosis systems are designed to reject up to 98.5% NaCl, unless computer projections have been run and provide a different rejection percentage.

The amount of purified water recovered for use is expressed as a percentage recovery. To calculate % recovery, use the following formula:

$$\% \text{ Recovery} = (\text{Product Water Flow Rate} / \text{Feed Water Flow Rate}) \times 100$$

NOTE: All Flow Rates must be expressed in the same units, usually gallons per minute (gpm).

Thunder commercial reverse osmosis systems are designed to have a minimum recovery of 50% and up to 70% when computer projections have been run.

System Requirements & Operation Guidelines

Plumbing

The membranes and high pressure pumps used on Thunder systems require a continuous and non-turbulent flow of water to the system with a minimum feed pressure of 35 psi, which does not exceed 105°F.

The piping used for the inlet of the concentrate is 1" FNPT. The piping used for the discharge of the concentrate is 1" FNPT and should be run to an open drain in a free and unrestricted manner.

The tubing or piping used for the permeate is 1" FNPT and can be transported to the holding tank or directly to the point-of-use through a PVC pipe, or other FDA accepted materials.

Material must not precipitate in the system. Be certain that all of the components of the feed water are soluble at the concentrations attained in the system. A system operating at 50% recovery, concentrates all impurities by twice the amount. If the feed water contains a slightly soluble material such as calcium sulfate, silica, or colloidal clay, an anti-sealant should be used.

CAUTION: Any restrictions or blockage in the drain can cause backpressure, which will increase the system's operating pressure. This can result in damage to the system's components.

Electrical

The motors used on Thunder 10000, 15000, & 20000 systems are pump and motor combinations. The Titan™ 10000 and 150000 are available in 1 phase 220 volt at 60 hertz or 220 volt at 50 hertz at an additional charge. The Thunder 20000 is available in 3 phase 220 volt at 60 hertz.

Please ensure that the electrical circuit supplying the system is compatible with the requirements of the specific Thunder model.

NOTE: We recommend that a licensed electrician install your system in accordance with local and national electrical codes.

WARNING: To reduce the risk of electrical shock, the incoming power supply must include a protective earth ground.

Each Thunder system is equipped with a 5 foot electrical cord.

Pre-Filtration

These Thunder systems are supplied with a 10 Micron FSI Bag Filter which filters sediment to a level of 10 microns. The 4.5" x 20" 5 Micron polypropylene filter removes particles over 5 microns. Change the cartridge at least every month or whenever needed. A chlorine removal system must be installed before

the system. Ask your local dealer or distributor about Water Softeners and/or Filtration systems.

NOTE: The system must be operated on filtered water only. Do not attempt to clean used filter cartridges.

CAUTION: If the pre-filter becomes clogged and the water flow to the pump is reduced or interrupted, cavitation will occur. This will damage the pump.

Pump

The pumps used on Thunder 10000, 15000, & 20000 systems are pump and motor combinations. They are multi-stage centrifugal pumps. Follow these guidelines to ensure proper operation of the pump:

- The pump must NEVER be run dry. Operating the pump without sufficient feed water will damage the pump.
- **ALWAYS** feed the pump with filtered water. The pump is susceptible to damage from sediment and debris.

Mounting

The free standing system should be bolted down in compliance to local regulation standards or securely fastened.

Membrane Elements

Thunder reverse osmosis systems come preloaded with Thin Film Composite High Flow membranes unless otherwise specified. General membrane element performance characteristics are listed below:

Membrane Element Characteristics			
Operating Pressure	150psi	Maximum Pressure	400 psi
Nominal % Rejection	98.5%	Chlorine Tolerance	<1 ppm
Maximum Temperature:	110°F	Turbidity	1 NTU
Silt Density Index	5 SDI	pH Range	3-11

Test Conditions: Permeate flow and salt rejection based on 550 TDS, 150 psi, 77°F (25°C), pH 7, and recovery as indicated. **NOTE:** Higher TDS and/or lower temperatures will reduce the system's production.

Start-Up

Unless otherwise indicated, these instructions cover the Thunder 10000, 15000, & 20000 reverse osmosis systems. Please refer to the flow diagrams and exploded view diagrams found in this User's Manual for additional information.

Installation

These Thunder reverse osmosis systems are mounted onto a station which is on caster wheels. These wheels must be securely locked or fastened and (placed on an even floor, so that the system will not vibrate or move. If this occurs, place the system on a rubber mat to reduce the vibrations and movement. If you remove the caster wheels from the system's frame then properly mount the system to the ground.

Carefully inspect your system before start-up. Check all plumbing and electrical connections. Connections may have come loose during shipment.

A User's Manual, Test Results, and Filter Housing Wrench will accompany your Thunder reverse osmosis system.

Start-Up

1. Locate the 2" FNPT feed water inlet on the 18" FSI bag filter housing.
2. Attach the inlet piping to the 2" FNPT feed water inlet. Always maintain a smooth and sufficient flow of feed water during operation.
3. Locate the 1" FNPT permeate outlet.
4. Attach the permeate piping to the permeate outlet. Make sure that the permeate water can flow freely and that there is no backpressure. Backpressure can cause damage to the membrane elements.

CAUTION: The plumbing in the permeate line can contaminate the high quality water produced by the system; ensure that the components are compatible with the application. The pH of the reverse osmosis permeate will normally be 1-2 points lower than the feed water pH. A low pH can be very aggressive to some plumbing materials, such as copper piping.

5. Locate the concentrate (waste) outlet. Locate the concentrate outlet on the drain side of the concentrate control valve.
6. Attach the drain line to the concentrate outlet.
7. Run the concentrate line to the drain. Water must be allowed to run freely, without any restrictions or blockage in the drain line. Make sure that no backpressure exists on the concentrate line.
8. Ensure that the electrical power requirements of the Thunder system match your electrical power supply.
9. Thunder systems are typically controlled with a liquid level switch in a storage tank. The liquid, level switch turns the system on when the water level in the tank drops, and off when the tank is full. If your reverse osmosis system is equipped with an electrical control box, the level control is connected to the level control connections in the control box. The level control connections are dry contacts and never apply power to these connections. Liquid level switches can be obtained by your local dealer or distributor. If a liquid level switch is to be used, install it at this time and turn the power to the Titan™ system on. Otherwise, turn the system on by plugging in the power cord. Allow the system to run for about three to five minutes with the concentrate control valve fully open to purge air from the system. Make sure that the concentrate re-circulate valve is closed.
10. The Thunder systems permeate or product water should be discarded for the first hour of operation. This will flush out any impurities which are in the system. Turn the concentrate control valve to the desired recovery rate. Follow any specified system projections in supplied. Flush the system at 50 psi for 15 minutes to remove the impurities from the system. Check for leaks and cracked fittings which may have occurred during shipment.
11. Connect the permeate line to the storage tank or point-of-use application. Make sure that no backpressure exists on the permeate line.

12. Locate the concentrate control valve and the concentrate pressure gauge.
13. Turn the concentrate control valve until the designated recovery is acquired. The concentrate pressure will increase as the concentrate control valve is closed. The exact operating pressure may vary depending on the temperature and TDS of your feed water. It may be necessary to re adjust the system if there is a major change in feed water temperature and/or TDS.
14. Turn the pump bypass valve until the correct pump pressure is achieved. For example a Titan™ 10000 should be adjusted until it produces about 10000 GPD or 6.94 GPM of permeate or product water.

$$\text{GPM} = \text{GPD}/1440$$

WARNING: Never exceed the maximum pressure rating of your pressure vessels.

Operation & Maintenance

The reverse osmosis process causes the concentration of impurities. The impurities may precipitate (come out of solution) when their concentration reaches saturation levels. **NOTE:** Precipitation can scale or foul membranes and must be prevented.

Check your feed water chemistry. Pre-treat the water and/or reduce the system recovery as required. If necessary, consult with your local dealer or distributor.

Pre-Filter Pressure Gauges

These gauges measure the feed water pressure when it enters and exits the pre-filter housing. A pressure differential of 15% or more on the two pressure readings indicates that the pre-filter needs to be replaced. For example, if the inlet pressure is 40 psi, the filter should be changed when the outlet pressure is 34 psi or below.

Product (Permeate) Flow Meter & Waste (Concentrate) Flow Meter

These flow meters indicate the flow rates of permeate and concentrate water. The measurements, when added together, also indicate the feed water flow rate; if the system is not equipped with a waste recycle.

Waste Recycle Valve

This valve allows you to recycle some of the concentrate water back to the feed of the pump. This will increase the recovery of the Thunder system. An optional waste recycle flow meter allows you to measure how much concentrate is recycled. The amount of waste water recycled is limited by the TDS of the feed water. The drawback of using concentrate recirculate is an increase of total dissolved solids in the permeate water. **CAUTION:** Excessive recycling may cause premature fouling or scaling of the membrane elements.

Low Pressure Switch

The low pressure switch shuts off the system and sounds an alarm when the feed water pressure drops too low for the system to function properly. This prevents damage to the pump. The system restarts automatically when the pressure is restored. If you notice the pressure fluctuating, and the system cycling

off and on, turn the system off and ensure that proper feed flow and pressure are available to the system. For further information, please review the computer controller's manual.

Low Pressure Shut-Off Switch

The low pressure protection circuit can be located on the back panel of your Thunder system. The low pressure shut-off switch monitors the system's feed water pressure and will shut off the system and sound alarm if pressure loss is detected.

Auto-Flush

The auto-flush option bypasses the concentrate control valve, reducing the concentrate pressure and increasing the flow of feed water across the membrane. The auto-flush removes foulants that may have attached to the surface of the membrane. By removing these foulants before they crystallize on the surface of the membrane, the system can operate longer without cleaning and/or replacing the membrane elements. The following are instances in which the auto-flush should be utilized:

1. When injecting antiscalant chemicals. These chemicals keep scaling ions in solution up to a higher concentration so the ions don't precipitate, and scale the membrane elements. If the solubility concentration is exceeded, the ions may precipitate and scale the membrane.
2. For feed water with a high scaling potential (hard water) in addition to the auto-flush, pre-treat the water with an antiscalant or a water softener. Do not use the automatic fast flush instead of pretreatment.
3. Where minimal maintenance is important, auto-flush can increase the time between membranes cleaning.
4. For high TDS (total dissolved solids) applications where the TDS exceeds 500 ppm, consider upgrading system to auto-flush.
5. For higher recovery applications (that use a recycle valve), consider using auto-flush.
6. For systems that may remain inoperative for long periods of time, auto-flush should be installed. The auto-flush will not operate if the electrical power is removed from the system.

The auto-flush feature includes an adjustable setting that regulates its operation. In the auto-flush mode the water will flush across the membrane in the same direction as the water flows in normal operation; this is not a backwash flow.

NOTE: Some permeate will be produced during the auto-flush; therefore, an overflow for the permeate storage tank is recommended.

Pump Bypass Valve

This valve is installed as a standard feature on the Thunder 10000, 15000, & 20000 reverse osmosis systems. It provides an adjustment for pump pressure, which will vary as the required system pressure changes. Note that with a multi-stage pump, the pump flow decreases as the operating pressure increases.

As the feed water temperature decreases, and/or the feed water TDS increases, the system will require a higher operating pressure to produce the specified permeate flow. A Thunder system installed in Florida may provide the specified permeate flow of 3.47 gpm at 150 psi; however the same system installed in Maine - much colder feed water - may require 190 psi to produce the same amount of permeate. The

system in Florida would have a higher concentrate flow to the drain because of the lower operating pressure, which would result in poor system recovery.

$$\% \text{ Rejection} = (\text{Feed IDS} - \text{Product TDS}) / (\text{Feed IDS}) \times 100$$

Membrane Removal & Replacement

Changing membranes in pressure vessels is an easy process if you have the proper information and tools at hand. Please refer to the following instructions when removing and replacing membrane elements:

1. Remove the end caps from the top of the membrane housings. This is done by removing the white Nylon snap ring of the Champ housing or unscrewing the bolts of the PuroTech housing, which holds on the clamp.
2. Remove the membrane bag containing the membrane element from the shipping box.
3. Cut the bag open as close as possible to the seal at the end of the bag, so the bag may be re used if necessary.
4. Remove the membrane element from the bag and remove the black core tube protectors from each end of the membrane.
5. Remove parts from the parts container (if included) and inspect. Make sure that all parts are clean and free from dirt. Examine the brine seal, and permeate tube for nicks or cuts. Replace the O-rings or brine seal if damaged.
6. Flow directions should be observed for installation of each element in each housing.

As time progresses, the efficiency of the membrane will be reduced. In general, the salt rejection does not change significantly until two or three years after installation when operated on properly pretreated feed water. The permeate flow rate will begin to decline slightly after one year of operation, but can be extended with diligent flushing and cleaning of the system. A high pH and/or precipitation of hardness can cause premature loss in rejection of membrane elements in the system.

To replace the membrane elements:

1. Remove all of the membrane element(s) from the membrane element housings from the top of the housing. Heavy-duty pliers and channel lock pliers may be necessary to pull the old membrane element out of the membrane element housing.
2. Install the brine seal side of the membrane elements first. When the housings have a direction of flow from bottom to top, the brine seal should be located on the end of the membrane element at the bottom of the housing.
3. Lubricate the brine seal with a food grade lubricant.
4. At a slight angle insert membrane while slightly rotating element being careful not to tear or flip the brine seal. Re-lube the brine seal if necessary.
5. With a smooth and constant motion, push the membrane element into the housing so that the brine seal enters the housing without coming out of the brine seal groove. A slow twisting motion should be used to insert the membrane element, to ensure that the brine seal stays in place.

6. Re-install the end caps by gently twisting the end cap while pushing it onto the housing. Ensure that you do not pinch or fatigue any O-rings while pushing the end plug on. Push the end plug on until the outer diameter of the plug is flush with the outer diameter of the membrane housing.
7. Insert nylon snap ring until fully seated. Snap ring must be able to be spun in place if fully seated. If you are using a stainless steel housing, install the clamps halves, and tighten bolts until the clamp halves meet.
8. Reconnect any fittings that may have been disconnected when the membrane element housings were disassembled.
9. To Start-Up the system, refer to Start-Up

CAUTION: New or factory cleaned membranes are shipped in a preservative solution. New or cleaned membranes must be flushed for at least 1 hour to remove the preservative from the membrane. Discard all of the permeate and concentrate, which is produced during the flush.

Membrane Cleaning

Periodic cleaning of the membrane(s) can improve system performance. In normal operation, mineral scale, biological matter, colloidal particles, and organic substances can foul the membranes.

WARNING: Cleaning chemicals are dangerous and can cause injury and damage to the environment. Read and comply with all safety and disposal precautions listed on the Material Safety Data Sheets (MSDS's). It is the user's responsibility to comply with all applicable federal, state, and local regulations.

Organic Foulant Cleaning

The following cleaning procedures are designed specifically for membranes that have been fouled with organic matter. Review the general cleaning instructions for information that is common to all types of cleaning such as suggested equipment, pH and temperature limits, and recommended flow rates.

Safety Precautions

1. When using any chemical indicated here in subsequent sections, follow accepted safety practices. Consult the chemical manufacturer for detailed information about safety, handling and disposal.
2. When preparing cleaning solutions, ensure that all chemicals are dissolved and well mixed before circulating the solutions through the membrane elements.
3. It is recommended the membrane elements be flushed with good-quality chlorine-free water after cleaning. Permeate water is recommended; but a de-chlorinated potable supply or pre-filtered feed water may be used, provided that there are no corrosion problems in the piping system. Operate initially at reduced flow and pressure, to flush the bulk of the cleaning solution from the elements before resuming normal operating pressures and flows. Despite this precaution, cleaning chemicals will be present on the permeate side following cleaning. Therefore, permeate must be diverted to drain for at least 10 minutes or until the water is clear when starting up after cleaning.
4. During recirculation of cleaning solutions, the temperatures must not exceed 50 °C at pH 2-10, 35 °C at pH 1-11, and 30 °C at pH 1-12.
5. For membrane elements greater than six inches in diameter, the flow direction during cleaning must be the same as during normal operation to prevent element telescoping, because the

housing thrust ring is installed only on the reject end of the housing. This is also recommended for smaller elements.

Cleaning Procedures

There are seven steps in cleaning membrane elements with organics.

1. Make up the cleaning solution listed from Table 1.

Table 1: Organic Cleaning Solution

- Preferred 0.1 % (wt) Soda Ash
- « PH 12, 30°C maximum
- Preferred 0.1 % (wt) NaOH 0.025% (wt)
- PH 12, 30°C maximum

Notes:

- 1 (wt) Denotes weight percent of active ingredient.
- 2 Cleaning chemical symbols in order used: NaOH is sodium hydroxide.

Cleaning the Organics from Membrane Elements

2. Low-flow pumping. Pump mixed, preheated cleaning solution to the vessel at conditions of low flow rate (about half of that shown in Table 2) and low pressure to displace the process water. Use only enough pressure to compensate for the pressure drop from feed to concentrate. The pressure should be low enough that essentially no permeate is produced. A low pressure minimizes re-deposition of dirt on the membrane. Dump the concentrate, as necessary, to prevent dilution of the cleaning solution.

Table 2: Recommended Feed Flow Rate Per Housing During High Flow Rate Re-Circulation

- Dependent on number of elements in pressure vessel.
 - 4-Inch full-fit elements should be cleaned at 12-14 gpm (2.7-3.2 m³/hr).
3. Re-circulate. After the process water is displaced, cleaning solution will be present in the concentrate stream that can be recycled to the cleaning solution tank. Recycle the cleaning solution for 15 minutes or until there is no visible color change. If a color change occurs, dispose of the cleaning solution and prepare a new solution as described in step 2.
 4. Soak. Turn the pump off and allow the elements to soak. Soak the elements for 1-15 hours (soaking overnight will give best results). To maintain temperature during an extended soak period, use a slow recirculation rate (about 10 percent of that shown in Table 2). Soak time will vary depending on the severity of the fouling. For lightly fouled systems, a soak time of 1-2 hours is sufficient.
 5. High-flow pumping. Feed the cleaning solution at the rates shown in Table 2 for 45 minutes. The high flow rate flushes out the foulants removed from the membrane surface by the cleaning. If the elements are heavily fouled, using a flow rate that is 50 percent higher than shown in Table 2 may aid cleaning. At higher flow rates, excessive pressure drop may be a problem. The maximum recommended pressure drops are 15 psi per element or 50 psi per multi-element vessel, whichever value is more limiting.
 6. Flush out. Prefiltered raw water can be used for flushing out the cleaning solution, unless there will be corrosion problems (e.g., stagnant seawater will corrode stainless steel piping). To prevent precipitation, the minimum flush out temperature is 20°C. The system should be flushed for 1 hour.

7. The system should be restarted. Elements and the system need to stabilize before taking any data. The stabilization period will vary depending on the severity of the fouling. To regain optimum performance, it may take several cleaning and soak cycles.

NOTE: Recommendations made here are specifically designed for the membrane elements inserted in the Titan™ reverse osmosis and nanofiltration elements. These recommendations, such as cleaning procedures and chemicals employed, may not be compatible with other brands of membrane elements. It is your responsibility to ensure the suitability of these recommendations and procedures if they are applied to membrane elements other than those which come with your system.

NOTE: No freedom from any patent owned by Seller or others is to be inferred. Because use conditions and applicable laws may differ from one location to another and may change with time, Customer is responsible for determining whether products and the information in this document are appropriate for Customer's use and for ensuring that Customer's workplace and disposal practices are in compliance with applicable laws and other governmental enactments. Seller assumes no obligation or liability for the information in this document. **NO WARRANTIES ARE GIVEN; ALL IMPLIED WARRANTIES OF MERCHANTABILITY OR FITNESS FOR A PARTICULAR PURPOSE ARE EXPRESSLY EXCLUDED.**

Additional Information

By experience, the cleaning solution of Na₄EDTA with caustic has been found to be slightly less effective than a standard caustic solution or a solution of caustic and Na-DSS. For any solution, contact time is critical. Several overnight soaks may be necessary to restore the system performance. After the elements are clean it is very beneficial to clean one additional time in order to clean off the last remaining biofilm layer on the surface of the membrane. Any remaining biofilm will tend to attract and trap dirt, so an extra cleaning will increase the time between cleanings. For industrial systems where the permeate or product water is not used for drinking, a non-oxidizing biocide can be used prior to step 1 of the cleaning procedure to kill any bacteria or biofilm in the system. Please refer to separate instructions on methods for sanitizing membrane systems (i.e., "Sanitization with DBNPA - Tech Facts"). If the only choice for a sanitizing agent is an oxidant, such as hydrogen peroxide, the system must be cleaned before sanitization.

Inorganic Foulant Cleaning

The following cleaning procedures are designed specifically for membranes that have been fouled with organic matter. Review the general cleaning instructions for information that is common to all types of cleaning such as suggested equipment, pH and temperature limits, and recommended flow rates.

Safety Precautions

1. When using any chemical indicated here in subsequent sections, follow accepted safety practices. Consult the chemical manufacturer for detailed information about safety, handling and disposal.
2. When preparing cleaning solutions, ensure that all chemicals are dissolved and well mixed before circulating the solutions through the membrane elements.
3. It is recommended the membrane elements be flushed with good-quality chlorine-free water after cleaning. Permeate water is recommended; but a de-chlorinated potable supply or pre-filtered feed water may be used, provided that there are no corrosion problems in the piping system. Operate initially at reduced flow and pressure, to flush the bulk of the cleaning solution from the elements before resuming normal operating pressures and flows. Despite this precaution, cleaning chemicals will be present on the permeate side following cleaning. Therefore, permeate must be diverted to drain for at least 10 minutes or until the water is clear when starting up after cleaning.

4. During recirculation of cleaning solutions, the temperatures must not exceed 50 °C at pH 2-10, 35 °C at pH 1-11, and 30 °C at pH 1-12.
5. For membrane elements greater than six inches in diameter, the flow direction during cleaning must be the same as during normal operation to prevent element telescoping, because the housing thrust ring is installed only on the reject end of the housing. This is also recommended for smaller elements.

Cleaning Procedures

There are seven steps in cleaning membrane elements with Inorganics.

1. Make up the cleaning solution listed from Table 1.

Table 1: Inorganic Cleaning Solution

- Preferred 2.0% (wt) Citric Acid PH 2, 45 °C maximum
- Alternate Muriatic Acid

Notes:

1 (wt) denotes weight percent of active ingredient.

2 Cleaning chemical symbols in order used: HCl is hydrochloric acid (Muriatic Acid).

Cleaning the Inorganics from Membrane Elements

- Alternative 1.0% N32S2O4
- Alternative 0.5% HsPCM

Form No. 609-00301-1202XQRP

Notes:

1 (wt) denotes weight percent of active ingredient.

2 Cleaning chemical symbols in order used: HCl is hydrochloric acid (Muriatic Acid).

2. Low-flow pumping. Pump mixed, preheated cleaning solution to the vessel at conditions of low flow rate (about half of that shown in Table 2) and low pressure to displace the process water. Use only enough pressure to compensate for the pressure drop from feed to concentrate. The pressure should be low enough that essentially no permeate is produced (approx. 60 psi). A low pressure minimizes redeposition of dirt on the membrane. Dump the concentrate, as necessary, to prevent dilution of the cleaning solution.

Table 2: Recommended Feed Flow Rate Per Housing During High Flow Rate Re-Circulation

Element Diameter	PSI	GPM
2.5 Inches	20-60	3-5
4 Inches	20-60	8-10

- Dependent on number of elements in pressure vessel.
 - 4-Inch full-fit elements should be cleaned at 12-14 gpm (2.7-3.2 m³/hr).
3. Re-circulate. After the process water is displaced, cleaning solution will be present in the concentrate stream that can be recycled to the cleaning solution tank. Recycle the cleaning solution for 10 minutes or until there is no visible color change. If at anytime during the circulation process there is a change in pH or a color change, dispose of the solution and prepare a new solution as described in step 2. A pH of 2 must be maintained for the cleaning to be effective.

4. Soak. Turn the pump off and allow the elements to soak. Soak the elements for 1-15 hours (soaking overnight will give best results). To maintain temperature during an extended soak period, use a slow recirculation rate (about 10 percent of that shown in Table 2). Soak time will vary depending on the severity of the scaling. For lightly scaled systems, a soak time of 1-2 hours is sufficient.
5. High-flow pumping. Feed the cleaning solution at the rates shown in Table 2 for 10 minutes. The high flow rate flushes out the foulants removed from the membrane surface by the cleaning. If the elements are heavily fouled, using a flow rate that is 50 percent higher than shown in Table 2 may aid cleaning. At higher flow rates, excessive pressure drop may be a problem. The maximum recommended pressure drops are 15 psi per element or 50 psi per multi-element vessel, whichever value is more limiting.
6. Flush out. Prefiltered raw water can be used for flushing out the cleaning solution, unless there will be corrosion problems (e.g., stagnant seawater will corrode stainless steel piping). To prevent precipitation, the minimum flush out temperature is 20 °C. The system should be flushed for one hour.
7. The system should be restarted. Elements and the system need to stabilize before taking any data. The stabilization period will vary depending on the severity of the fouling. To regain optimum performance, it may take several cleaning and soak cycles.

NOTE: Recommendations made here are specifically designed for the membrane elements inserted in the Titan™ reverse osmosis and nanofiltration elements. These recommendations, such as cleaning procedures and chemicals employed, may not be compatible with other brands of membrane elements. It is your responsibility to ensure the suitability of these recommendations and procedures if they are applied to membrane elements other than those which come with your system.

NOTE: No freedom from any patent owned by Seller or others is to be inferred. Because use conditions and applicable laws may differ from one location to another and may change with time, Customer is responsible for determining whether products and the information in this document are appropriate for Customer's use and for ensuring that Customer's workplace and disposal practices are in compliance with applicable laws and other governmental enactments. Seller assumes no obligation or liability for the information in this document. NO WARRANTIES ARE GIVEN; ALL IMPLIED WARRANTIES OF MERCHANTABILITY OR FITNESS FOR A PARTICULAR PURPOSE ARE EXPRESSLY EXCLUDED.

Additional Information

Never recirculate the cleaning solution for longer than 20 minutes. With longer recirculation, the carbonate scale can reprecipitate and end up back on the membrane surface, making it more difficult to clean. Carbonate scale reacts with HCl releasing carbon dioxide gas. Depending on the severity of the fouling, it may take repeated cleanings to remove all the scale. Cleaning severe scale may not be economical and element replacement may be the best choice.

Citric acid was originally used as a cleaner for cellulose acetate membranes and is not as effective with thin film composite chemistry. Further, it has a disadvantage of being a nutrient source for systems, which have biological fouling. It is, however, easier to handle than HCl and is included as the primary cleaner for that reason.

Flushing the System

The system should be flushed weekly to remove sediment from the surface of the membranes. To manually flush the system following the preceding steps:

1. The system must be running during the flushing procedure.

2. Open the concentrate valve until the pressure gauge reads approximately 50 psi (3.5 bar).
NOTE: If pressure will not drop to approximately 50 psi (3.5 bar) pressure during flushing, the concentrate valve must be cleaned.
3. Allow the system to run for 10 to 20 minutes.
4. After 10 to 20 minutes, close the concentrate valve to its previous position, raising the operating pressure to 150 psi. Ensure the proper concentrate flow rate is going to the drain.
5. The system is now ready to operate.

Draining the System for Shipment

Prior to shipping or storing your system, the system should be cleaned with an appropriate cleaner, flushed with water, and protected from biological attack with an appropriate solution for membrane elements. The membrane housing(s) and plumbing lines of the system must be completely drained. Any water remaining in the plumbing of a system may freeze, causing serious damage. The party shipping or storing the system is responsible for any damage resulting from freezing.

To drain the system:

1. Disconnect the inlet, concentrate, pre-filter, and permeate plumbing.
2. Drain all water from the pre-filter cartridge housings by unscrewing the housings, removing the pre-filter cartridges, and drain the water from the housings.
3. Disconnect the tubing from the connector on the permeate and concentrate inlets and outlets.
4. Fully open the concentrate valve.
5. Drain the flow meters by disconnecting the tubing from the bottom fitting of each meter.
6. Allow the system to drain for a minimum of eight hours or until the opened ports quit dripping.
7. After draining is complete, reconnect all of the plumbing.

Troubleshooting

If the system production declines or the system stops working, check the mechanical components for any visual problems. Listed below are the items to check for any visual problems. Listed below are the items to check for two of the most commonly encountered problem conditions: Low system pressure and abnormal permeate flow. Also refer to the reverse osmosis troubleshooting matrix on the next page.

Low System Pressure

Low system pressure occurs when sufficient feed water pressure and flow are not obtained. This causes the high-pressure reverse osmosis pump to cavitate. Failure to provide the proper feed will result in lower system pressure that may result in low production and poor rejection. Check the following components:

1. Pump:

Isolate the pump and determine how much pressure can be achieved. This can be determined by checking the pump discharge pressure gauge at this point. If the system is not equipped with this gauge, disconnect the hose that runs from the pump to the pressure vessel. Install a

pressure gauge. The pressure of the pump must reach at least 190 psi when the flow is restricted.

2. Pre-Filter:

Check the differential in the pre-filter gauges to determine if the filter needs to be replaced. If the system is not equipped with these gauges, examine the pre-filter cartridge to make sure that it is not clogged and does not restrict feed flow to the pump. Replace, if necessary.

3. Low Feed Water Flow Rate:

Determine that the system is getting a sufficient volume of feed water. Disconnect the feed water hose from the system and place it in a one gallon bucket. Measure the time it takes to fill the bucket to determine the feed flow. (Feed flow is measured in gallons per minute, so divide 1 gallon by the time in minutes to obtain the flow rate). Refer to the System Specifications for the required feed flow.

4. Inlet Solenoid Valve:

Feed water enters the system through an automatic solenoid shut-off valve, which is normally closed. Ensure that the solenoid opens when the reverse osmosis pump starts. The system can be operated without the solenoid for troubleshooting. Remove the solenoid to see if it is contributing to the problem. Normally, cleaning the solenoid diaphragm will correct any malfunction of the solenoid.

5. Electric:

Check to ensure that there are no electrical fuses blown and that all electrical connections are secure. Use a voltmeter to verify that the motor is getting sufficient power.

6. Pressure Gauge:

Check for foreign matter on the gauge fitting. Remove any visible matter and replace the fitting. Verify that the tube is not pushed too far inside the fitting. This could restrict flow and cause an inaccurate display. If the fitting and tube are fine and the pressure gauge is still malfunctioning, the gauge should be replaced.

7. Concentrate Control Valve:

The concentrate control valve may have a tear in the diaphragm. Remove the valve, inspect the diaphragm, and replace if necessary.

8. Motor:

The motor may not be drawing the correct current. Use a clamp-on amp meter to check the current draw.

9. Leaks:

Check the system for leaks, as this can result in low pressure.

Abnormal Permeate Flow

Permeate flow should be within 15% of the rated production, after correcting the feed water temperatures above or below 77 °F. Check your permeate flow meter to determine the permeate flow rate. If the system does not have a permeate flow meter, measure the time it takes to fill a 1 gallon container then calculate the permeate flow rate at gallons per minute or gallons per day.

Reverse Osmosis System Troubleshooting

Symptoms			Location	Possible Causes	Verification	Corrective Action
Salt Passage	Permeate Flow	Pressure Drop				
Normal to Increased	Decreased	Normal to Increased	Predominately First Stage	Metal Oxide Fouling	Analysis of Metal Ions in Cleaning Solution.	Improve pretreatment to remove metals. Clean with Acid Cleaners.
Normal to Increased	Decreased	Increased	Predominately First Stage	Colloidal Fouling	SDI Measurement of Feed Water.	Optimize pretreatment for colloid removal. Clean with high pH anionic cleaners.
Increased	Decreased	Increased	Predominately First Stage	Scaling (CaSO ₄ , CaSOS, BaSO ₄ , SiO ₂)	Analysis of metal ions in cleaning solution by checking LSI of reject. Calculate max. solubility of CaSO ₄ , BaSO ₄ , SiO ₂ in reject.	Increase acid addition and antiscalant dosage for CaVOS and CaCO ₄ . Reduce recovery. Clean with Acid Cleaners.
Normal to Moderate Increase	Decreased	Normal to Moderate Increase	Any Stage	Biological Fouling	Bacteria count in permeate and reject. Slime in pipes and pressure vessels.	Shock dosage of Sodium Bi-Sulfate. Continuous feed of Sodium Bi-Sulfate at reduced pH. Formaldehyde disinfection. Chlorination and de-chlorination. Replace cartridge filters.
Decreased or Slightly Increased	Decreased	Normal	Any Stage	Organic Fouling	Destructive Element Testing.	Activated Carbon or other pretreatment. Clean with high pH cleaner.
Increased	Increased	Decreased	Most Severe in First Stage	Chlorine Oxidation	Chlorine Analysis of feed water. Destructive element test.	Check Chlorine feed equipment and de-chlorination system.
Increased	Increased	Decreased	Most Severe in First Stage	Abrasion of membrane by Crystalline Material	Microscopic solids analysis of feed. Destructive element test.	Improve pretreatment. Check all filters for media leakage.
Increased	Normal to Increased	Decreased	At Random	O-Ring Leaks, End or Side Seal Leaks	Probe test. Vacuum test. Colloidal material test.	Replace O-Rings. Repair or replace elements.
Increased	Normal to Low	Decreased	At Random	Recovery Too High	Check Flows and Pressure Against Design Guidelines.	Reduce the recovery rate. Calibrate and/or add sensors.

Operation Log

Company: _____
 Location: _____
 Week Of: _____
 System Serial #: _____

Date of Start-Up: _____
 Date of Last Cleaning: _____
 Cleaning Formulation: _____

Date		
Time		
Hours of Operation		
Cartridge Filter Inlet Pressure (psi)		
Differential Pressure (psi)		
Permeate Pressure (psi)		
Feed Pressure (psi)		
Concentrate Pressure (psi)		
Differential Pressure (psi)		
Pump Discharge Pressure (psi)		
Permeate Flow (GPM)		
Concentrate Flow (GPM)		
Feed Flow (GPM)		
Recovery %		
Feed Temperature		
Feed Conductivity (mg/L)		
Permeate Conductivity (mg/L)		
Rejection %		
Feed pH		
Permeate pH		
Scale Inhibitor Feed (ppm)		
Acid Feed (ppm)		
Sodium Bisulfite Feed (ppm)		
Feed Water:		
Iron (mg/L)		
Free Chlorine (mg/L)		
Hardness (ppm CaCO₃)		
Turbidity (NTU)		

Notes:

Temperature Correction Factors For Membrane Flux

TEMPERATURE		CA	TF
•C	•F	(Cellulose Acetate)	(Thin Film Composite)
10°	50°	1.468	1.71!
11°	52°	1.429	1.648
12°	54°	1.391	1.588
13°	55°	1.355	1.530
14°	57°	1.320	1.475
15°	59°	1.286	1.422
16°	61°	1.253	1.371
17°	63°	1.221	1.323
18°	64°	1.190	1.276
19°	66°	1.160	1.232
20°	68°	1.132	1.189
21°	70°	1.104	1.148
22°	72°	1.076	1.109
23°	73°	1.050	1.071
24°	75°	1.025	1.035
25°	77°	1.000	1.000
26°	79°	0.988	0.971
27°	81°	0.976	0.943
28°	82°	0.964	0.915
29°	84°	0.953	0.889
30°	86°	0.942	0.863

To use: Simply multiply the actual flux to obtain temperature corrected flux.

Service Assistance

If service assistance is required, take the following steps:

1. Call your distributor.
 - a. Prior to making the call, have the following information available:
 - i. Machine installation date
 - ii. Serial number (found on left-hand side of front panel)
 - iii. Daily Log Sheets
 - iv. Current operating parameters (i.e., flow, operating pressures, pH, etc.)
 - v. Detailed description of problem

Warranty & Guarantee

The manufacturer of your Thunder reverse osmosis system guarantees that the proposed product is to be free from defects in material or workmanship when operated in accordance with written instructions for a period of one year from start-up or fifteen months from receipt, whichever is shorter. Parts that are not manufactured directly by the manufacturer of your reverse osmosis system will be covered by their manufacturer's warranties which are normally for one year.

The manufacturer's membrane elements are guaranteed to operate within specifications when used for general water treatment for a period of 12 months from receipt providing the membrane elements have not been abused by operating at high temperatures, high or low pH's, on un-disinfected water, or on solutions which tend to precipitate.

For applications or water conditions other than those specified in the original purchase order for the reverse osmosis system, the User should consult with their local dealer or distributor to access the suitability of the solution to be run in the membrane elements.

Limitations on pH and temperature can vary with membrane element type and the application of the equipment. For special applications or for pH or temperature ranges outside the stated limits, the manufacturer may reduce the warranty period at their discretion.

A membrane element which fails to perform satisfactorily within the first 90 days after receipt, has not been mishandled, and is returned to the factory, will be replaced free of charge except for freight and local labor. If a membrane element fails to perform satisfactorily during the balance of the warranty period and with the return of the membrane element to the factory, the manufacturer will replace the membrane element with a new membrane element and will charge the User for the portion of the 12 months that the membrane element was used plus incoming freight and local labor. Such pro-rated charges will be based on the list price prevailing at the time of warranty consideration. A new membrane element supplied under warranty terms will carry the standard 12 month new membrane element warranty.

If a membrane element is to be returned for warranty inspection, the User must obtain a Return Good Authorization (RGA) number from their dealer or distributor before returning the membrane elements. Completely fill out a Return Merchandise Form, which will accompany the returned good. Membrane elements are to be returned freight prepaid to the manufacturer.

The manufacturer will return any warranty replacement membrane elements to the customer prepaid. Membrane elements must be kept damp at all times and must be clean and bagged in a watertight bag before returning. Only the manufacturer approved cleaners, biocides, dispersants or other chemicals may be used with the membrane elements. Use of other chemicals may void the warranty. The User is responsible for knowing the membrane element material and for ensuring that chemicals harmful to the membrane element are never in contact with the membrane elements.

It is the obligation of the User to maintain frequent operating data records. The manufacturer may request these records in the warranty evaluation. The User must notify their dealer or distributor at the very first sign of changes in operation of the system or membrane elements. Such notification should be in writing and should include all data requested on the operating log sheets.

To obtain a copy of the manufacturer's warranty for their systems and terms and conditions, please contact your local dealer and distributor.



CRYSTAL QUEST® Thunder Reverse Osmosis

Thunder 10,000

	6	CHAMP 4" X 40" HOUSING PART# 200530	(A1)
	6	THIN FILM COMPOSITE MEMBRANE (TFC) 4" X 40" (LP) PART# 200379	(A2)
	12	END PLUG 4" PART# 200596	(A3)
	12	SNAP RING 4" PART# 200597	(A4)
	12	4" O-RING KIT PART# 200599	(A5)
	2	0-300 P.S.I. PRESSURE GAUGE PART# 200904	(B)
	1	COMPUTER CONTROL S-150 PART# 200859(120 VAC)/200860(220VAC)	(C)
	2	CONTROL VALVE / RECYCLE VALVE 1" SS PART# 200995	(D)
	2	0-160 P.S.I. PRESSURE GAUGE PART# 200901	(E)
	1	20" BIG GRAY PRE-FILTER HOUSING PART# 200731	(F)
	1	5 MICRON SEDIMENT FILTER PART# 200650	(F1)
	1	3 HP COULDS PUMP 110/220 VOLT PART# 200790	(G)
	1	SOLENOID VALVE 110/220 VOLT PART# 200914(120VAC)/200915(220VAC)	(H)
	1	LOW PRESSURE SWITCH PART# 200905	(I)
	1	POWDER COATED EPOXY FRAME PART# N/A	(J)
OPTIONAL	3	RECYCLE FLOW METER 10 GPM PART# 200899	(K)
	1	FILTER HOUSING FSI PART# 200739	(L)
	1	18" FSI BAG FILTER 10MICRON PART# 200710	(M)
OPTIONAL	2	AUTO-FLUSH PART# 200042	(N)

Thunder 15,000

	8	CHAMP 4" X 40" HOUSING PART# 200530	(A1)
	8	THIN FILM COMPOSITE MEMBRANE (TFC) 4" X 40" (LP) PART# 200379	(A2)
	16	END PLUG 4" PART# 200596	(A3)
	16	SNAP RING 4" PART# 200597	(A4)
	16	4" O-RING KIT PART# 200599	(A5)
	2	0-300 P.S.I. PRESSURE GAUGE PART# 200904	(B)
	1	COMPUTER CONTROL S-150 PART# 200859(120 VAC)/200860(220VAC)	(C)
	2	CONTROL VALVE / RECYCLE VALVE 1" SS PART# 200995	(D)
	2	0-160 P.S.I. PRESSURE GAUGE PART# 200901	(E)
	1	20" BIG GRAY PRE-FILTER HOUSING PART# 200731	(F)
	1	5 MICRON SEDIMENT FILTER PART# 200650	(F1)
	1	3 HP COULDS PUMP 110/220 VOLT PART# 200792	(G)
	1	SOLENOID VALVE 110/220 VOLT PART# 200914(120VAC)/200915(220VAC)	(H)
	1	LOW PRESSURE SWITCH PART# 200905	(I)
	1	POWDER COATED EPOXY FRAME PART# N/A	(J)
	2	FLOW METER 20 GPM PART# 200900	(K)
OPTIONAL	1	RECYCLE FLOW METER 10 GPM PART# 200899	(K1)
	1	FILTER HOUSING FSI PART# 200739	(L)
	1	18" FSI BAG FILTER 10MICRON PART# 200710	(M)
OPTIONAL	2	AUTO-FLUSH PART# 200042	(N)

Thunder 20,000

	10	CHAMP 4" X 40" HOUSING PART# 200530	(A1)
	10	THIN FILM COMPOSITE MEMBRANE (TFC) 4" X 40" (LP) PART# 200379	(A2)
	20	END PLUG 4" PART# 200596	(A3)
	20	SNAP RING 4" PART# 200597	(A4)
	20	4" O-RING KIT PART# 200599	(A5)
	2	0-300 P.S.I. PRESSURE GAUGE PART# 200904	(B)
	1	COMPUTER CONTROL S-150 PART# 200859(120 VAC)/200860(220VAC)	(C)
	2	CONTROL VALVE / RECYCLE VALVE 1" SS PART# 200995	(D)
	2	0-160 P.S.I. PRESSURE GAUGE PART# 200901	(E)
	1	20" BIG GRAY PRE-FILTER HOUSING PART# 200731	(F)
	1	5 MICRON SEDIMENT FILTER PART# 200650	(F1)
	1	5 HP GRUNDFOS PUMP 220/460 VOLT PART# N/A	(G)
	1	SOLENOID VALVE 110/220 VOLT PART# 200914(120VAC)/200915(220VAC)	(H)
	1	LOW PRESSURE SWITCH PART# 200905	(I)
	1	POWDER COATED EPOXY FRAME PART# N/A	(J)
	2	FLOW METER 20 GPM PART# 200900	(K)
OPTIONAL	1	RECYCLE FLOW METER 10 GPM PART# 200899	(K1)
	1	FILTER HOUSING FSI PART# 200739	(L)
	1	18" FSI BAG FILTER 10MICRON PART# 200710	(M)
OPTIONAL	2	AUTO-FLUSH PART# 200042	(N)

S-150

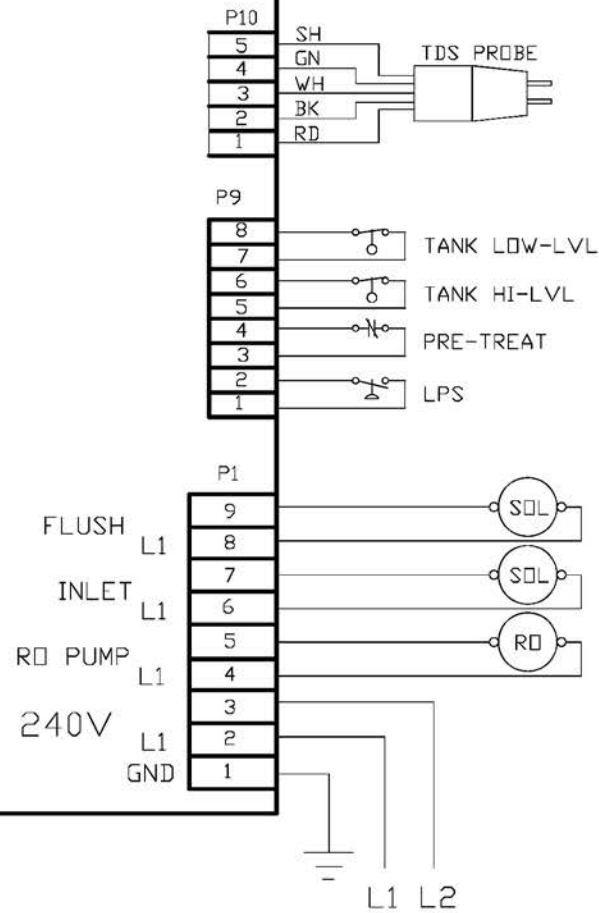

CAUTION!
DISCONNECT AND BRANCH
PROTECTION IS REQUIRED ON THE
POWER FEEDING THIS PANEL.

Thunder
10,000, 20,000 and 20,000

**Do not scale
drawing**

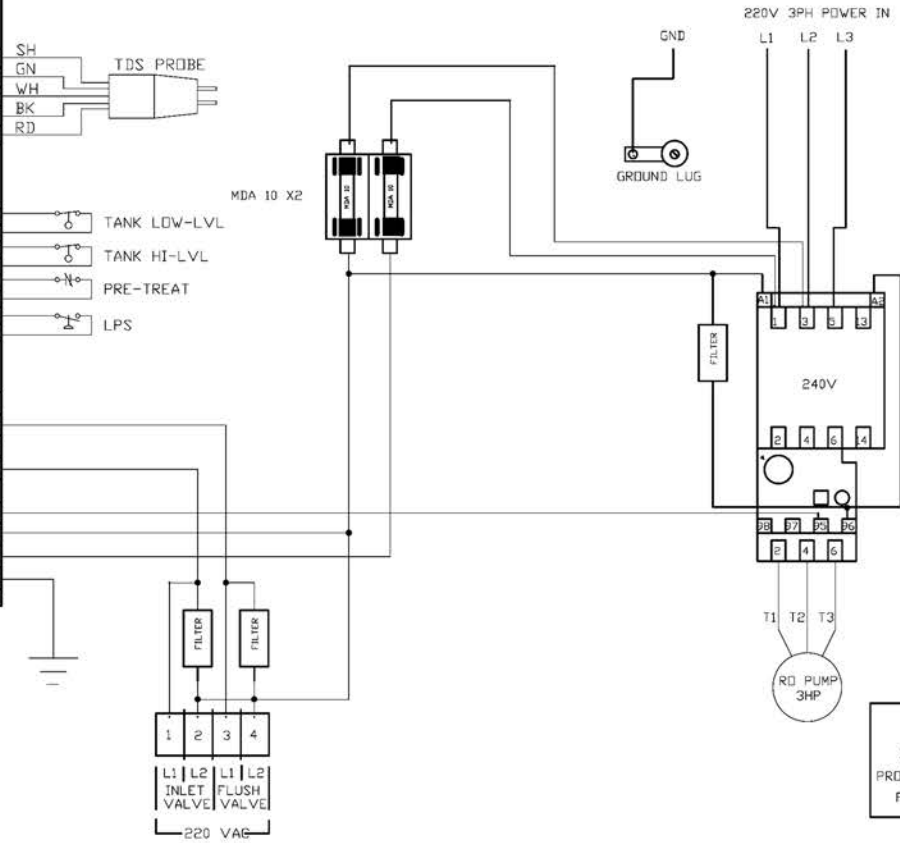
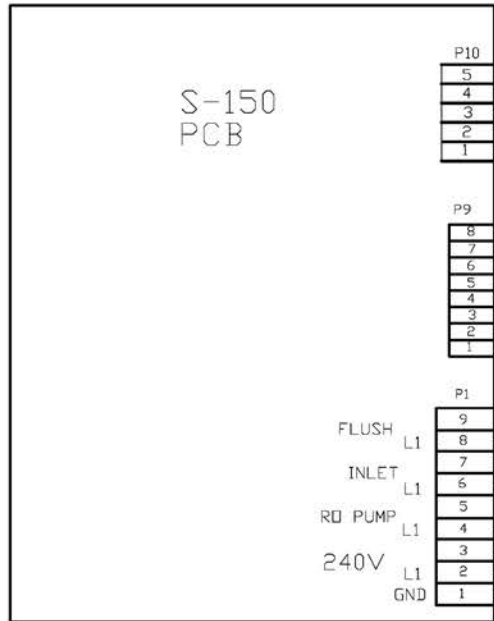

CAUTION!
 DISCONNECT AND BRANCH
 PROTECTION IS REQUIRED ON THE
 POWER FEEDING THIS PANEL.

CRYSTAL QUEST®
 Water Filters

Thunder
 10,000, 20,000 and 20,000

**Do not scale
 drawing**

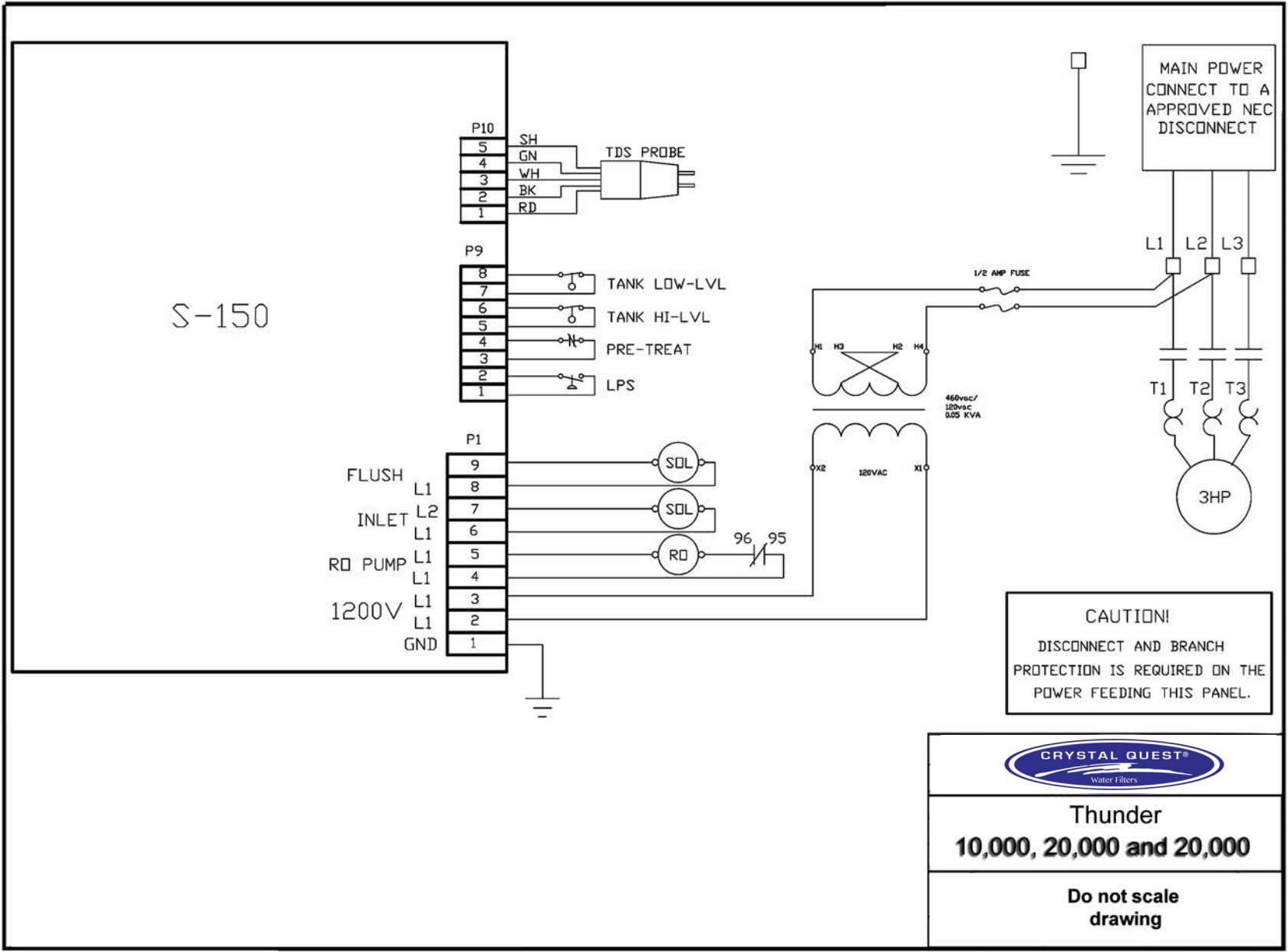

S-150

MAIN POWER
CONNECT TO A
APPROVED NEC
DISCONNECT

CAUTION!
DISCONNECT AND BRANCH
PROTECTION IS REQUIRED ON THE
POWER FEEDING THIS PANEL.



Thunder
10,000, 20,000 and 20,000

**Do not scale
drawing**



Authorized Distributor

Should service be required during or after the warranty period or should you have any questions regarding how to use your Commercial Water Purification System, please contact manufacturer's Technical Support Department Monday through Friday, 9 AM to 5 PM Eastern Time, or your authorized CRYSTAL QUEST dealer:



Mailing Address:
FilterWater.com
P.O. Box 968
Southampton, PA 18966
USA

<http://www.FilterWater.com>
Tel. +1 (800) 439-0263
Fax +1 (215) 354-0304
Email: Sales@filterwater.com