

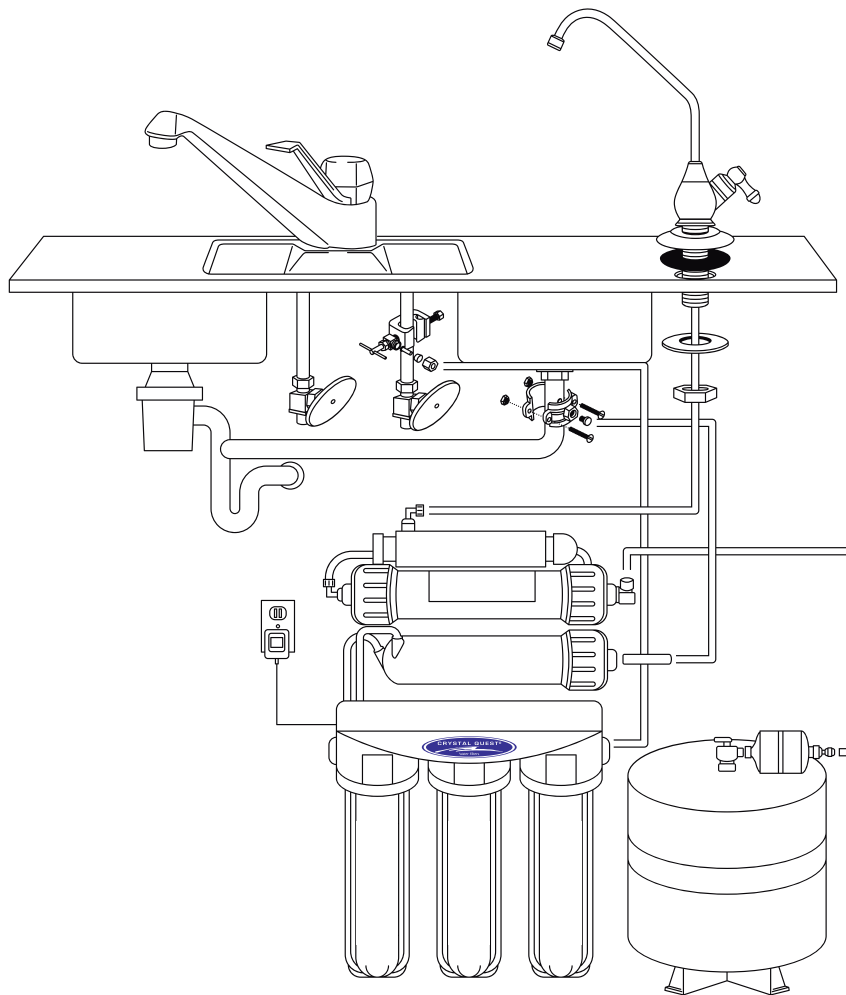

Crystal Quest® THUNDER® Series Reverse Osmosis Undersink Water Filter System INSTALLATION AND OPERATION GUIDE



Copyright 2017
Crystal Quest®
All rights reserved
MADE IN THE USA





i IMPORTANT INFORMATION

- Inspect the carton and unit for evidence of rough handling and concealed damages. If contents appear damaged, report damage to the carrier. Notify Shipper immediately.
- Remove components from shipping carton. Check that all installation parts are present, which includes the unit, storage tank, faucet, installation hardware, and tubing.
- Check that the air supply in the tank is approximately 7 psi. Adjust if necessary.
- Read the instructions carefully and learn the specific details regarding installation and use. Failure to follow them could cause serious property damage. Crystal Quest® accepts no liability for property damage.
- The system should be installed to meet local, state, and federal plumbing codes, and health department rules and regulations. The guidelines must be followed as the Reverse Osmosis system is installed.
- All equipment should be plumbed into the water system by a qualified, licensed plumber.
- Check with your local public works department for plumbing codes.
- Use the system on a potable (safe to drink) COLD water supply only.
- Note: It is recommended that a Under Sink Detector Smart Valve (CQE-PT-03060) be placed directly upstream of your household filter to prevent water damage.

TOOLS & MATERIALS

- Safety glasses
- 3/8" variable speed electric drill, 1/8" and 1/2" bits
- 1-1/4" porcelain hole cutter (if hole for second faucet is not provided)
- Extension cord, drop light or flashlight
- Plastic anchors and screws
- Plastic tube cutter
- Air pressure gauge (low pressure)
- Pliers
- Phillips head and flat head screwdrivers
- 1-1/4" wood bit
- Household bleach (liquid)
- Adjustable wrench
- Crescent wrench
- Thread seal tape
- Air pump (hand)

INSTALLATION STEPS

- Step 1 Install Faucet pg. 3
- Step 2 Install Saddle Valve pg. 4
- Step 3 Install Drain Connection pg. 4
- Step 4 Install Tank pg. 5

OPERATING SPECIFICATIONS:

Pressure Range: 30-60 psi (2.1-4.1 bar)
 Temperature Range: 40-85°F (4.4-29.4°C)
 Optimum Service Flow: 0.30 gpm at 60 psi (1.1 lpm at 4.1 bar)

ELECTRICAL REQUIREMENTS:

110V 50Hz (North and South America)
 220-240V 60Hz (Other Continents)

MODELS

1,000 C (CQE-RO-00101)	2,000 C (CQE-RO-00102)	3,000 C (CQE-RO-00103)	4,000 C (CQE-RO-00104)
1,000 CP (CQE-RO-00105)	2,000 CP (CQE-RO-00106)	3,000 CP (CQE-RO-00107)	4,000 CP (CQE-RO-00108)
1,000 M (CQE-RO-00109)	2,000 M (CQE-RO-00110)	3,000 M (CQE-RO-00111)	4,000 M (CQE-RO-00112)
1,000 MP (CQE-RO-00113)	2,000 MP (CQE-RO-00114)	3,000 MP (CQE-RO-00115)	4,000 MP (CQE-RO-00116)



IMPORTANT INFORMATION

The faucet to be used for your reverse osmosis system (RO) should be placed near the sink where drinking/cooking water is normally required. A **2" flat surface is required to mount the faucet** if an existing hole for a second faucet is not available. The mounting thickness should not exceed 1-1/4". If the sink has a sprayer, it may be disconnected for faucet installation. A pipe cap or plug will be necessary to seal the sprayer connection. If making the faucet mounting hole (if sprayer or second hole is not used), check to make sure the drill does not interfere with anything below. Center punch a small indent at the desired faucet location (2" flat surface is required, not exceeding 1-1/4" in thickness). Drill the required pilot hole of the chassis punch and tighten nut to cut the desired hole size. Clean up sharp edges. The faucet should be positioned so it empties into the sink and the spout swivels freely for convenience. If sink has a hole that can accommodate the RO faucet, no drilling is required. Proceed with mounting the faucet.

MOUNTING THE FAUCET:

Disassemble hardware from the threaded nipple, except for chrome base plates and rubber washers. (Rubber washers may be replaced with a bead or plumber's putty for neater appearance.) Feed the threaded nipple through sink or counter mounting hole and position the faucet. From below sink or counter, assemble the white spacer, flat washer, and hex nut on threaded nipple and tighten by hand (open end up; open side toward air gap). After checking faucet orientation, tighten with a wrench until secure (Fig 1).

INSTALL FOR STAINLESS STEEL SINKS

Recommended Tools:

- Center punch
- Variable speed drill
- High speed drill bits
- Chassis punch 7/8" (9/16" for non air gap faucets)
- Protective gloves and eye protectors

Procedures:

1. Center punch small indent for hole.
2. Drill the required pilot hole.
3. Set-up the chassis punch per instructions and tighten nut to cut the desired hole size.
4. Clean up sharp edges with file.

INSTALL FOR PORCELAIN, ENAMEL, CERAMIC ON METAL OR CAST IRON

Precautions must be taken to penetrate the porcelain through to the metal base and prevent it from chipping or scratching.

Recommended Tools:

- Variable speed drill
- Plumber's putty
- Porcelain cutter tool set (7/8" or alternative size, 9/16")

Procedures:

1. Mark the center for the 7/8" hole.
2. Form shallow putty around hole area and fill with enough water to lubricate carbide drill bit.
3. Carefully drill pilot hole through all layers (use light pressure and slow speed).
4. Insert pilot tip of spring-loaded porcelain cutter into pilot hole.
5. Drill porcelain/enamel disc down to the base metal. Make certain the cutter does not touch outer rim of the cut porcelain/enamel. Continue with this bit to cut through metal until sink has been completely penetrated.

NOTE: Always use sharpened porcelain cutter to eliminate chips and cracks.

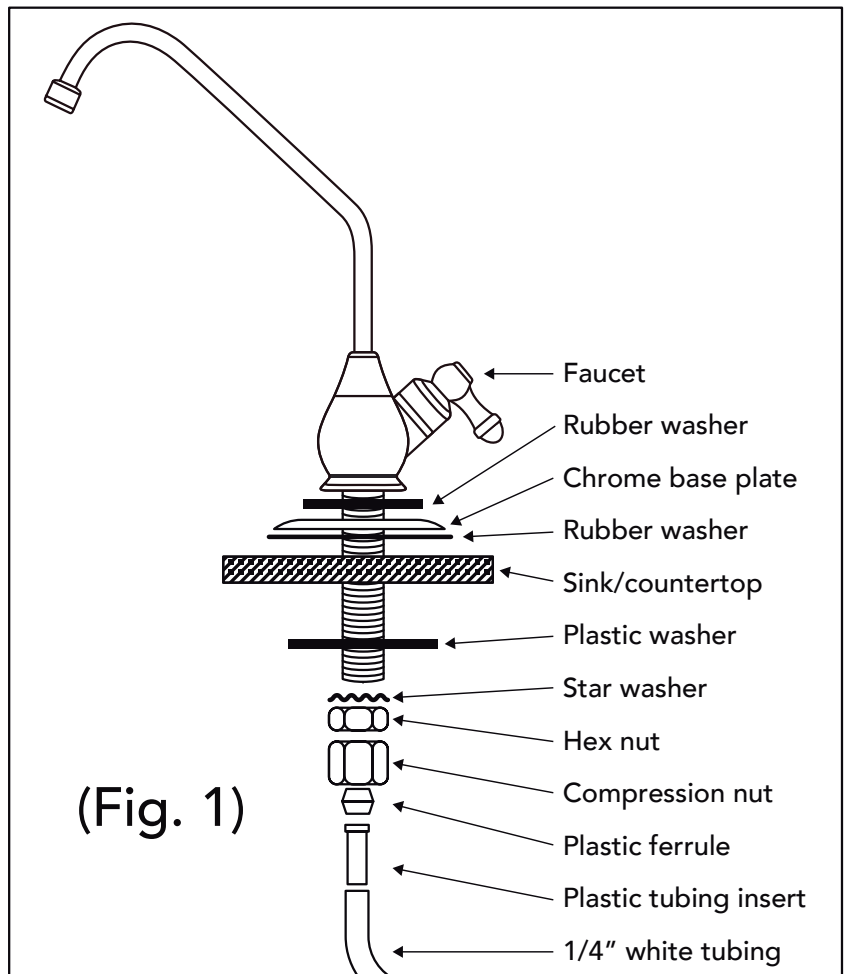



STEP 2: INSTALLING VALVE OPTIONS

SADDLE VALVE INSTALLATION

Choose the Valve Location:

- Choose a location for the valve that is easily accessible. It is best to connect into the side of a vertical water pipe. When it is necessary to connect into a horizontal water pipe, make the connection to the top or side, rather than at the bottom, to avoid drawing off any sediment from the water pipe.
- Disconnect the cold-water supply line. Attach and tighten the saddle valve connector assembly being careful not to pinch or crimp any tubing or water supply line while tightening. Use thread seal tape to ensure a tight fit.

NOTE: The saddle valve clamps onto soft or hard tubing or pipe. It will make its own hole in copper tubing but not in iron or brass. For brass or galvanized iron pipe, drill a 1/4" hole in pipe before mounting saddle valve. If possible, use a hand or cordless drill when drilling water pipe. If using electric drill, be sure that drill, cord, and outlet are all properly grounded.

NOTE: Do not turn handle before installing or while installing saddle valve. To prevent damage to piercing needle, make sure that piercing lance does not project beyond the rubber gasket.

NOTE: Leave handle in this position (valve closed) until filter installation is complete.

1. Hold backplate against tube.
2. Hold saddle valve against tubing in a position directly opposite backplate.
3. Tighten screw enough so saddle valve and backplate are held securely against tube.
4. Tighten screw firmly. Do not crush tube.

CONNECT SOURCE WATER FEED TUBING TO VALVE BODY USING COMPRESSION FITTING.

1. Slide nut and sleeve onto tubing (in that order).
2. Install insert into tubing.
3. Install tubing with insert and sleeve into valve body.
4. Thread compression nut onto valve body. Tighten.
5. Turn saddle-tapping valve handle clockwise until it is firmly seated and piercing lance is fully extended.

CAUTION: When the supply line is pierced, the valve should be closed. Do not open valve until system is activated.

Turn on cold water supply. Check saddle-tapping valve installation for leaks. Allow water to run from faucet for a few minutes to clear any debris in the line caused by installation.

NOTE: If flow from sink faucet is reduced, clean faucet aerator.

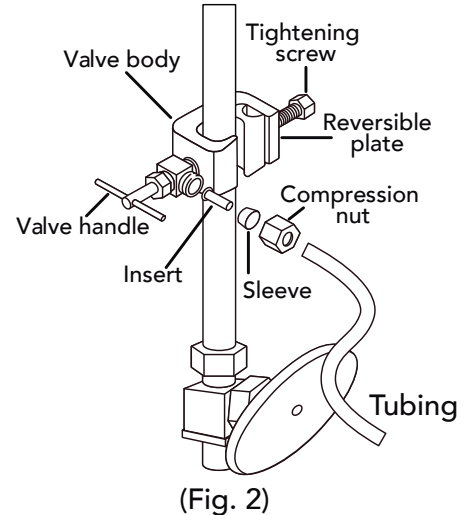

(Fig. 2)

T-VALVE INSTALLATION

WARNING: Water supply pressure must not exceed 60 psi.

NOTE: T-Valve is designed for installation on flex line tubing.

NOTE: Always check the local plumbing codes before tapping into a water line.

1. Turn off cold water supply.
2. Assemble T-Valve by screwing and tightening the shut-off valve into the water supply connector (use thread seal tape on threads).
3. Disconnect source water feed tubing from cold water supply.
4. Install T-Valve assembly in line with water feed tubing and water supply.
5. Remove nut from feed end of shut-off valve and slide over filter supply tubing.
6. Press end of tubing over exposed nipple on shut-off valve. Ensure it is completely seated.
7. Slide nut down tubing and tighten securely to shut-off valve.
8. Slowly turn cold water supply on and check for leaks.
9. Open T-Valve shut-off valve slowly to supply water to filter

For further instructions on T-Valve assembly, see T-Valve product label.

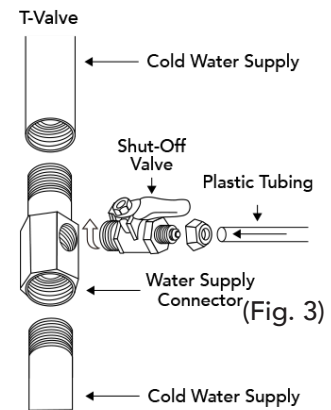

(Fig. 3)

STEP 3: INSTALL THE DRAIN CONNECTION

IMPORTANT: Before starting this procedure, inspect the condition of the drain piping, especially in older homes where the traps and tailpieces can be thin and frail. If in poor condition, it is wise to inform the customer that the condition should be remedied. The drain saddle assembly is designed to fit around a standard 1-1/2" OD drain pipe. The drain saddle should always be installed above (before) the trap and on the vertical or horizontal tailpiece. Never install the drain saddle close to the outlet of a garbage disposal, or plugging of the RO drain line may occur.

1. Peel adhesive covering from the back of foam square gasket, line up with the hole in the drain saddle, and apply. This gasket provides a leakproof seal on the drain pipe.
2. Position both halves of drain saddle at desired location on drain pipe.
3. Use screws and nuts to clamp drain saddle onto drain pipe. Do not overtighten or cross-thread, and make sure there is equal space between saddle halves on each side.
4. Carefully drill hole through the fitting front hole of drain saddle, being careful not to drill through opposite side of drain pipe.
5. Wrap thread seal tape on threads of fitting (if any), insert drain tubing into drain saddle, and tighten nut if it is a compression fitting.

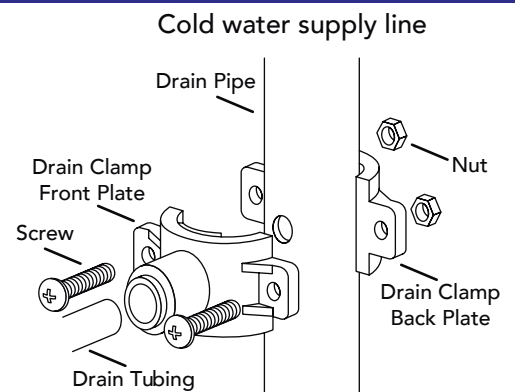

(Fig. 4)



STEP 4: INSTALL THE STORAGE TANK

Hand tighten tank ball shut-off valve to tank, connect tubing.

PREFILL AND SANITIZE THE STORAGE TANK

Prefilling the tank is always recommended so there is pressure to check for leaks and several gallons of water to flush the carbon post-filter. Tanks are furnished with a special disinfectant and only require filling with water for 15 minutes to be completely sanitized. It is important to use a sanitizer when prefilling the tank so the solution can sanitize the tubing, fittings, and faucet at the time of installation and startup.

1. Insert free end of feedwater tubing into the fitting on the storage tank.
2. Open feedwater valve and tank valve and allow tank to fill (about 3 minutes).
3. Turn off feed water valve and tank valve. Remove tank from tubing and set the tank aside (15 minutes minimum).

INSTALL THE REVERSE OSMOSIS AND STORAGE TANK

The RO is usually mounted to the right or left sink cabinet sidewall, taking into consideration the space available and the tank location. Generally, the tank is placed in the rear of the cabinet while the RO is positioned toward the front for cartridge accessibility. To mount the RO, elevate at least 2" off the cabinet floor and, while keeping level, mark the location of the mounting holes on cabinet sidewall. Make small pilot holes with an awl or drill, and screw in the two mounting screws, leaving just enough protrusion to allow bracket mounting slots to slide over them.

NOTE: If the cabinet sidewalls are not of solid construction, the unit can be set on the cabinet floor and held against the sidewall with the mounting screws. The tank may be oriented either vertically or horizontally. It is generally placed to the rear of the cabinet but can be set in the front center (between the sink basins) for ease of access, if space permits.

Tank ball shut-off valve

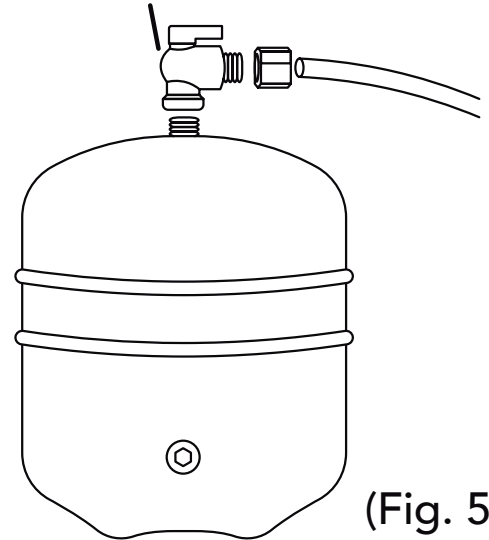

(Fig. 5)

MAKE FINAL TUBING CONNECTIONS

With all of the components in place, the final tubing connections can be made. When routing tubing between components, several guidelines should be observed.

- Tubing runs should generally follow the contour of the cabinet rather than interfere with the cabinet storage area.
- Strive for neatness and an orderly tubing "flow" using fasteners to secure the tubing. Cut tubing to the desired length.
- Arrange the tubing so that there are no sharp bends and leave some "play" in the tubing for ease of servicing.
- Keep the tubing from the RO to the tank and faucet as short as practical for good flow.

INSTALL ICEMAKER HOOKUP (OPTIONAL)

The RO drinking water appliance can be connected to any standard refrigerator icemaker or icemaker/water dispenser. It should never be connected to a commercial ice maker. Hooking up an icemaker involves connecting a tee with shut-off valve into the faucet tubing and routing tubing to the refrigerator. Do not hook up to existing copper tubing. Before turning off the existing tap water supply to a refrigerator icemaker, always shut off the icemaker first (usually by lifting the lever arm above the bin to the uppermost position). The icemaker should only be turned on again after the RO system has been drained several times and the tank has a full supply of water.

NOTE: Before any service is performed on the RO system, always turn off icemaker valve and the icemaker unit. Turn on only when system is operating and tank is full. Be sure water is properly alkalined for refrigerator feed lines.

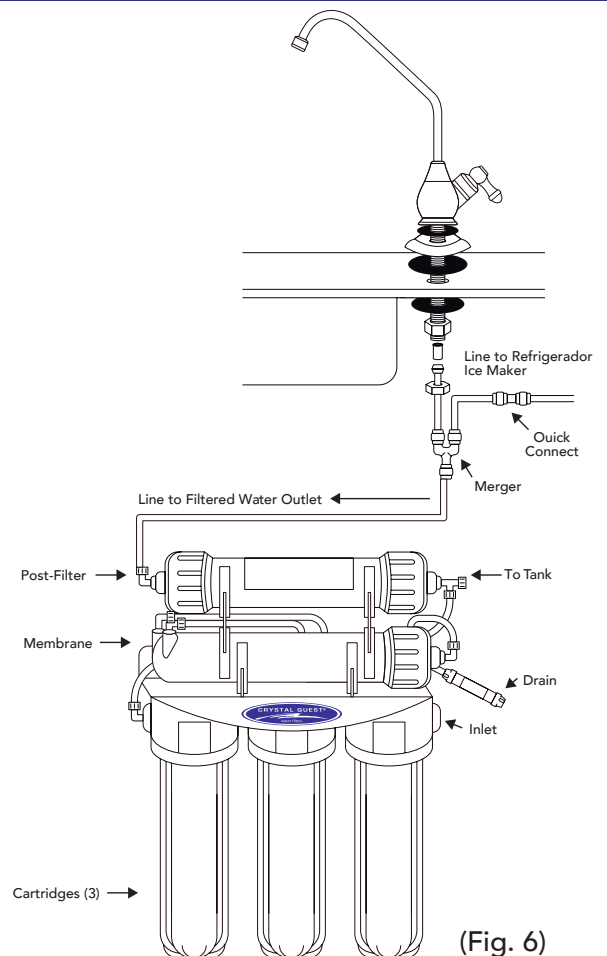

(Fig. 6)



STARTING UP THE SYSTEM

- Double check that all connections are secure.
- Turn on feedwater valve and check for leaks. If any leaks are noted, turn off valve and correct before proceeding.
- Turn on storage tank valve and open faucet until a steady stream of water flows. Close faucet. Wait at least 5 minutes and carefully check for leaks.

FLUSH SYSTEM OF SANITIZING SOLUTION AND CHECK OPERATION

- Lift faucet handle and allow tank to drain completely of sanitizing solution. DO NOT USE THIS WATER. When tank is empty, the faucet will steadily drip. This is the rate water is processed by the RO system.
- With faucet in "off" position, measure the rate of the steady drip from spout. Use a graduated cylinder (in milliliters) and watch with a second hand to calculate approximate product in gallons per day (milliliters per minute X 0.38 = gpd). Proceed to check reject flow rate by disconnecting tubing at drain connection and measure as per above. The ratio should be a minimum of 2.5 (reject) to 1 (product).
- Close faucet and re-inspect system for leaks. Instruct customer to wait at least 4 hours and drain tank again. The water should be discarded, as it may contain some sanitizing/disinfectant solution.
- System should be ready to use as soon as the tank refills. If any objectionable taste is noticed after second tank draining, instruct customer to wait and drain tank the following day. Only at this time should an icemaker be turned on if one is connected to the system.

OPERATION AND MAINTENANCE

Normal Operation

- It is normal for the Total Dissolved Solids (TDS) of the water to be high than normal during the first 5 gallons of operation. This is due to the sanitizing solution and the new post filter. After this rinse water has drained, the removal rate should stabilize at a value greater than 75%. Water pressure affects the production rate and quality.
- RO systems produce drinking water at relatively slow rates. It can take up to 8 hours or more to fill the holding tank. Normal operation is to let the holding tank fill with water and then draw water as needed. When the pressure in the holding tank falls to a given pressure (as the water is being used), the automatic shut-off valve will start water production and the system will refill the holding tank. When the holding tank is full and no water is being used, the automatic shut-off valve will automatically shut off the feedwater to conserve water. The more water that is used (up to the capacity of the system), the better the RO system will function. Utilize the water for other uses, such as flowers, pets, and rinsing glassware. After periods of non-use, such as a week's vacation, empty the holding tank and allow the system to produce fresh water. If the system is not used for 3-4 weeks or longer, it is a good idea to re-sanitize the system and to change the carbon and sediment cartridges.

WATER LEAKS

Your system has been tested before leaving the factory. In the unlikely event of a fault, small leaks sometimes do occur as a result of incorrect assembly or abuse. The following tips may be helpful:

- Depending on the positioning of the filter and the temperature of the incoming water and air, condensation on the outside of the filter housing may occur, resulting in a frosted appearance of fine water droplets on the surface. This does not, of course, mean that there is a leak in the system. The remedy is to either insulate the area around the filter or reposition it.
- Leaks can occur if cartridge is not installed properly. Cartridge must be installed according to the directional arrow on the cartridge which indicates "This End Towards Cap".
- Always ensure that sump top is snapped into sump by being pushed in.
- Always ensure that the sump ring is screwed fully onto the sump top. This is essential both for the internal seal and the housing seal. Use thread seal tape around sump if necessary.
- In the event of a leak, carefully examine its source. Water from a leak may run along the pipe work. (It may drip or collect some distance from the actual location of the leak.)
- Leaks occurring at the line saddle valve may mean that the unit has not been fully clamped onto the water line. (Adhere to the instructions given on page 4.)
- Leaks at the quick fittings are usually due to the tubing not being pushed fully into the fitting. Remove the tubing, cut off an inch of tubing with a sharp knife and reinsert into the quick fitting. Ensure that the quick fit collet is in position. When fitted correctly, the tube should not pull out of the fitting (unless the collet is pushed in at the same time to release the tubing).
- If there are leaks at the compression fittings, make sure that the components are fitted correctly and that the compression nuts are fully tightened.
- If there is a leak from the body of the faucet, check that the tap outlet arm is pushed down firmly. Two O-rings are fitting to the faucet outlet spout; ensure they are still in position.
- If there is a leak from the water filter inlet and outlet, unscrew fitting, wrap thread seal tape around it, and screw it back.

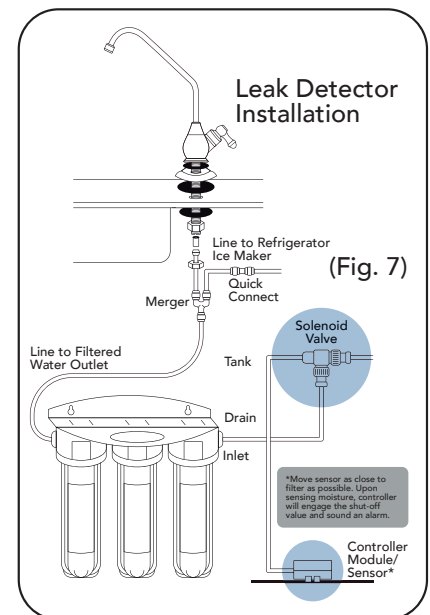



CHANGING POST FILTER & MEMBRANE

CHANGING POST FILTER CARTRIDGES

1. Loosen the connector fitting counterclockwise (Fig 8).
2. Pull the cartridge out of the main fold.
3. Wrap the connector fitting with thread seal tape and connect it to a new cartridge (Fig 9).

CHANGING MEMBRANE

1. Loosen the connector fitting counterclockwise (Fig 10).
2. Remove the membrane housing cap counterclockwise.
3. Remove the membrane with a pincer (Fig 11).
4. Insert the membrane by carefully pushing the spigot and into the socket at the far end of the housing until completely seated (Fig 12).
5. Wrap the connector fitting with thread seal tape and connect it to the tubing (Fig 13).

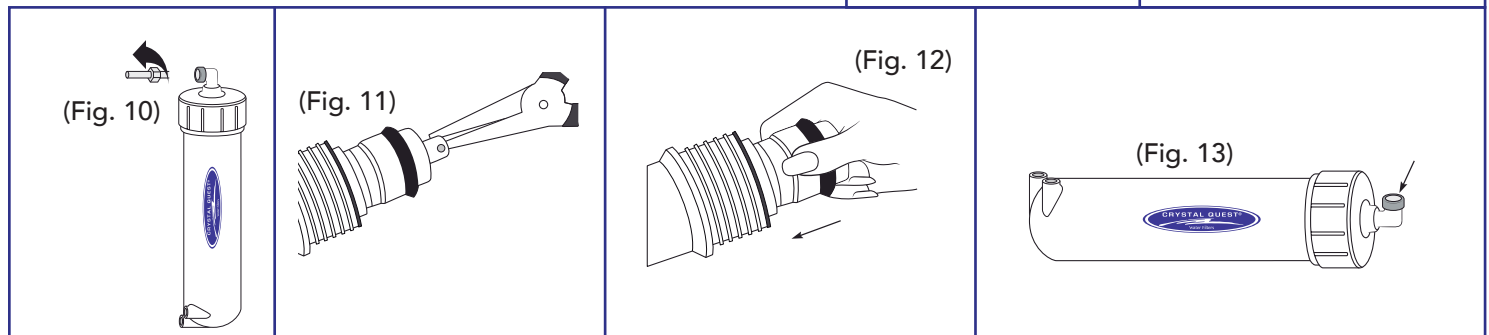
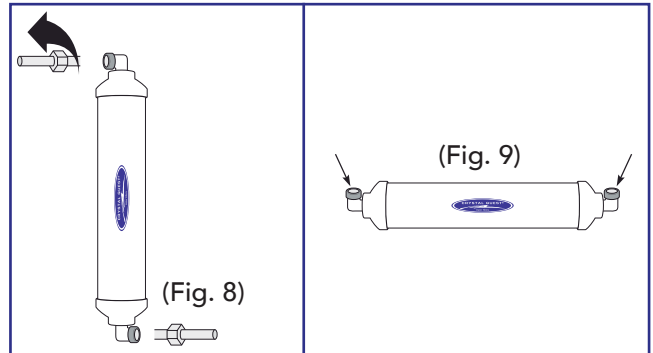

CHANGING CARTRIDGES

NOTE: THIS RO SYSTEM CONTAINS CARTRIDGES WHICH MUST BE REPLACED AT REGULAR INTERVALS. TO MAINTAIN PROPER PERFORMANCE USE ONLY FACTORY APPROVED CARTRIDGES.

Use a drip pan to catch any water that might spill when the filter housings are removed.

- 1) Close the saddle-tapping valve by turning fully clockwise and open the dispensing faucet by lifting the handle. Allow the holding tank to empty.
- 2) Loosen (TURN COUNTERCLOCKWISE TO LOOSEN and TURN CLOCKWISE TO TIGHTEN) and remove the appropriate filter housing. Discard the cartridge(s) (Fig 11).

Sanitize the system and replace the filter cartridge(s).

NOTE: The system should be sanitized before installing the post filter cartridge.

- 3) Wash the inside of the housing(s) using a mild detergent and a soft cloth. Do not use abrasive cleaners or pads. Thoroughly rinse all soap from the housing before reassembly.
 - a. Use a good quality 5-1/4 percent liquid bleach, such as Clorox®.
 - b. Add one capful of bleach (2 teaspoons/10 milliliters) to the sediment filter housing. Install the sediment prefilter only. Check the housing O-ring for proper position in its groove. Replace sediment filter housing on RO assembly.
 - c. If your RO system has a carbon prefilter housing, add one capful of bleach. Carefully fill the housing with tap water and temporarily install the housing, without the activated carbon prefilter housing.
 - d. Add one capful of bleach to the post filter housing. Carefully fill the housing with tap water and temporarily install the housing, without the post filter.
 - e. The dispensing faucet should be open. Slowly open the saddle-tapping valve on the feedwater line.
 - f. As soon as water begins to drip out of the dispensing faucet, close the faucet.
 - g. Let the system stand for 15 minutes.
 - h. After 15 minutes, (1) close the saddle-tapping valve, (2) close the holding tank valve, and (3) open the dispensing faucet to release the pressure.
 - i. Remove the post-filter housing and empty (repeat procedure if your system has a pre-filter housing).
- 4) Remove any wrapping/packaging from carbon cartridges and install in housings. Check the O-ring to ensure that it is positioned properly in its groove and replace housing(s) on RO unit.
- 5) Disconnect the water tubing that runs from the holding tank. Put 50 drops (1/2 teaspoon/3 milliliters) of bleach into the tubing and reconnect it.
- 6) Slowly open the saddle-tapping valve. When water begins dripping out of the dispensing faucet, (a) close the faucet and (b) open the holding tank valve.
- 7) Do not open the faucet for at least 8 hours.
- 8) Discard the first two full tanks of water produces, as they will contain chlorine.
- 9) When the faucet is first opened, expect air and carbon fines (very fine black powder) from the new carbon filter(s) to be rinsed out. This is normal for the first tank of water.

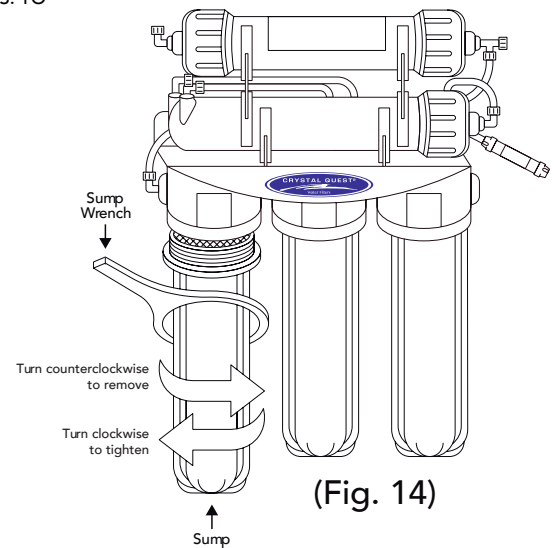

To change the UV bulb, follow instructions provided in the UV Guide.



TO ORDER REPLACEMENT CARTRIDGES

Item No. CQE-RC-04000 5-Micron Carbon Block Filter Cartridge
Item No. CQE-RC-04001 5-Micron Sediment Reusable Pleated Filter Cartridge
Item No. CQE-RC-04002 2-7/8" x 9-3/4" SMART PLUS Filter Cartridge
Item No. CQE-RC-04055 2-7/8" x 9-3/4" UF Membrane Filter Cartridge
Item No. CQE-RC-04038 Water Cooler/ Reverse Osmosis GAC Filter Cartridge
Item No. CQE-RC-04040 Water Cooler/ Reverse Osmosis SMART Filter Cartridge
Item No. CQE-RC-04054 Natural (Alkalizer) Ionizer, Mineralizer, and Oxidation Cartridge

Item No. CQE-RC-04006 2-7/8" x 9-3/4" Fluoride Filter Cartridge
Item No. CQE-RC-04049 2-7/8" x 9-3/4" SMART Fluoride Cartridge
Item No. CQE-RC-04007 2-7/8" x 9-3/4" Nitrate Filter Cartridge
Item No. CQE-RC-04050 2-7/8" x 9-3/4" SMART Nitrate Cartridge
Item No. CQE-RC-04008 2-7/8" x 9-3/4" Arsenic Filter Cartridge
Item No. CQE-RC-04051 2-7/8" x 9-3/4" SMART Arsenic Cartridge

ONE-YEAR LIMITED WARRANTY

CRYSTAL QUEST® warrants your CRYSTAL QUEST® THUNDER® Undersink Reverse Osmosis System for one year from the date of purchase against all defects in materials and workmanship when used in compliance with the manual. This warranty does not include replacement cartridges unless defective upon receipt. CRYSTAL QUEST® disclaims all implied warranties including, without limitation, warranties of merchantability and fitness for a particular purpose. If for any reason the product proves to be defective within one year from the date of purchase, please call for assistance. This warranty gives you specific legal rights and you may have other legal rights which vary from state to state. CRYSTAL QUEST® assumes no responsibility for incidental or consequential damages; for damages arising out of misuse of the product, or the use of any unauthorized attachment. Some states do not allow the exclusion or limitation of implied warranties or incidental or consequential damages; therefore, the above limitations or exclusions may not apply to you. Should service be required during or after the warranty period or should you have any questions regarding how to use your CRYSTAL QUEST® THUNDER® Undersink Reverse Osmosis System, please contact our Technical Support Department at service@crystalquest.com, Monday through Friday, 9 AM to 5 PM Eastern Time.

KEEP THIS MANUAL FOR FUTURE REFERENCE AND UNIT MAINTENANCE

Online warranty information
<http://crystalquest.com/warranty.htm>

Product design is subject to change without notice.

For further assistance, contact your Crystal Quest dealer
or visit us at www.crystalquest.com

To view the latest edition of the Mega Undersink Water Filter, visit CrystalQuest.com

Please note all drawings, pictures, colors and sizes are approximate for illustrative purposes only and may not exactly resemble the end product.



AUTHORIZED DISTRIBUTOR

Should service be required during or after the warranty period or should you have any questions regarding how to use your Commercial Water Purification System, please contact manufacturer's Technical Support Department Monday through Friday, 9 AM to 5 PM Eastern Time, or your authorized CRYSTAL QUEST dealer:



Mailing Address:

FilterWater.com

P.O. Box 968

Southampton, PA 18966

USA

<http://www.FilterWater.com>

Tel. +1 (800) 439-0263

Fax +1 (215) 354-0304

Email: Sales@filterwater.com