

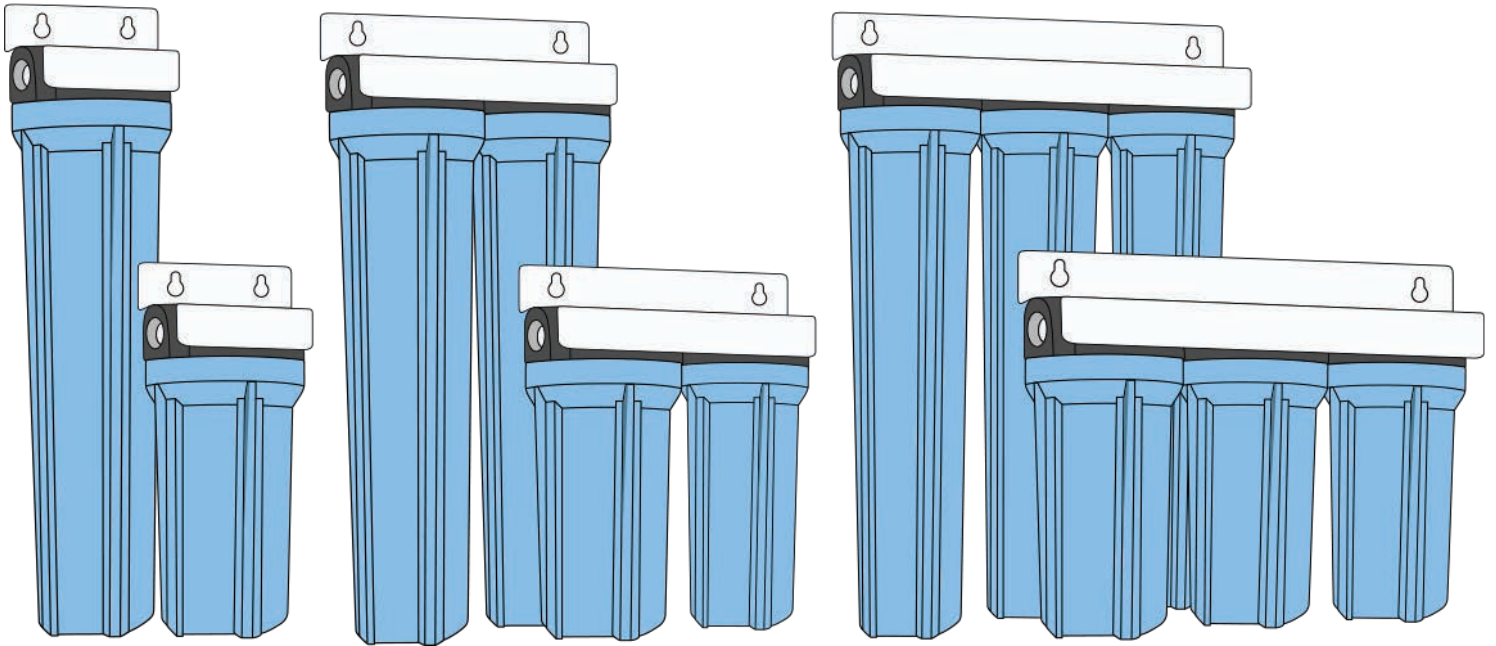

# Crystal Quest® Point-of-Entry (POE) Whole House Compact Water Filter Systems INSTALLATION AND OPERATION GUIDE



Copyright 2017  
Crystal Quest®  
All rights reserved.  
MADE IN THE USA





## TABLE OF CONTENTS

Important Information .....	2
Safety Precautions .....	3
Installing the Ground Wire .....	3
Installation on Whole House Main Water Pipe Using Soldered Copper Fittings .....	4
Installation on Whole House Main Water Pipe Using Threaded Pipe Fittings .....	5
Installation Diagram of Whole House Compact Water Filter System .....	6
Changing Cartridges .....	7
Cartridge Orientation/Arrangement .....	7
To Order Replacement Cartridges .....	7
Compact Whole House Water Filter Systems Model Numbers .....	7
One-Year Limited Warranty .....	8

## ! IMPORTANT INFORMATION

- Inspect the carton and unit for evidence of rough handling and concealed damages. If contents appear damaged, ask driver or contact carrier for a damage claim form to fill out. Shipper must be notified immediately.
- Remove components from shipping carton. Check that all installation parts are present, which includes the unit and installation hardware.
- This system should be installed to meet *local, state, and federal plumbing codes* and health department rules and regulations. Check with your state and local Public Works Department for plumbing and sanitation codes. These guidelines must be followed as you install the water filtration system.
- All Crystal Quest® water filtration systems should be installed by a licensed plumber or other qualified contractor. Not using the service of a plumber may void the warranty. Crystal Quest® assumes no liability whatsoever for systems improperly installed or those installed by anyone other than a qualified, licensed plumber.
- Do not use with water that is microbiologically unsafe or of an unknown quality without adequate disinfection before or after using the system.
- Your Whole House Compact system will stand up to 60 pounds per square inch (psi) water pressure. If house water supply pressure is higher than 60 psi, install a working pressure reducing valve before installing system. The most common residential operating range is 35-65 psi.
- Turn off the water flow to the house while installing the system.
- Refer to this guide and/or other labels for more information.

System color may vary (i.e., brown, blue, white, etc.)

### Operating Specifications

Pressure Range:	30-60 psi (2.1-4.1 bar)
Temperature Range:	40-100°F (4.4-37.7°C)
Optimum Service Flow:	3-8gpm*

\*Depending on size of system



## SAFETY PRECAUTIONS

Read all instructions carefully to learn the details for installing and using your whole house water filter system. Failure to follow the Installation and Operation Guide could cause bodily injury and/or property damage.

- Do not install on hot water line.
- Cold water use only.
- Use the system on a potable (safe-to-drink) COLD water supply only.
- Change cartridges routinely.
- Do not cross-thread fittings or housings. If cross-threaded, place the unit out of service.
- If the water flow slows or stops, replace cartridges.
- Check installation frequently for first week to make sure no leaks have developed.
- If away for over 72 hours, put the system in bypass mode.
- Device is to be installed downstream of pressure reduction valve before filter.
- Keep away from chemicals.
- Read the instructions carefully and learn the specific details regarding installation and use. Failure to follow them could cause serious property damage. Crystal Quest® accepts no liability for property damage.
- A Leak Detector Valve is recommended to avoid accidental property damage.
- Review Installation Diagram of Compact Whole House (Page 6) before starting installation.

**CAUTION:** The rubber O-ring provides a watertight seal between the cap and the bottom of the housing. Make sure the O-ring is properly seated in the groove below the threads of the housing or a water leak could occur.

**CAUTION:** Housings may crack in time, causing failure and leakage if exposed to organic solvents, such as those found in aerosol sprays for cleaning products and insecticides.

- The contaminants or other substances removed or reduced by the selected cartridge(s) are not necessarily in your water. Ask your local water municipality for a copy of their water analysis, or have your water tested by a reputable water lab.
- After prolonged periods of non-use (such as during a vacation), it is recommended that the system be flushed thoroughly. Let water run for 5-6 minutes before using.
- The filter cartridge(s) used with this system has a limited service life. Changes in taste, odor, color, and/or flow of the water indicate that the cartridge should be replaced.

This Compact Whole House Water Filtration System Installation and Operation Guide has instructions for installation on your house main water pipe using: (A) **compression fittings**; (B) **soldered copper fittings**; (C) **threaded pipe and fittings**. For each installation, refer to the appropriate illustrations.

### FOR ALL INSTALLATIONS

1. **Decide where to locate the water filter housing.** Select a location for the filter that is:  
(1) Protected from freezing; (2) Not exposed to direct sunlight or high heat.
2. Place a shut-off valve on both sides of the filter (**recommended**).
3. Place shut-off valves directly upstream of your household filter (**recommended**).
4. Place Whole House Leak Detector Smart Valve (CQE-WH-03064) directly upstream of your household filter to avoid water damage (**recommended**).
5. **Plan your installation.** Consider some of the following variables:
  - Water filter housing inlet and outlet internal threads
  - Existing plumbing type (copper, threaded, etc.) and nominal size (3/4", 1", etc.)
  - Tools needed, plumbing skills, cost of materials needed
  - Space availability (make a simple sketch of your proposed installation and a list of plumbing materials)

**NOTE:** Pipe, Shut-offs valves, and fittings are not provided by Crystal Quest®.

## WARNING

A copper or galvanized cold water pipe may be used to ground electrical outlets in the home. **Grounding protects you from electrical shock.** Failure to maintain this ground path may result in an electric shock hazard. If the cold-water pipe is used to ground electrical outlets, refer to "Installing the Ground Wire" section before cutting the pipe.

## INSTALLING THE GROUND WIRE

**NOTE:** If your house plumbing is PVC, it would not be used as a grounding path, and this step should be skipped.

**IMPORTANT:** A copper or galvanized house cold water pipe is often used to ground electrical outlets in the home. **Grounding protects you from electrical shock.** The water filter housing may have broken this ground path. To restore connection, install an 18" long, 6-gauge copper wire across the filter, tightly clamped using UL approved 1/2"-1" bronze grounding clamps at both ends as shown. **Zinc clamps should not be used on copper plumbing.** Wire and clamps may be purchased separately from your local hardware store.

- Clean copper pipe and ends of wire with emery cloth. Bare wire is recommended. If insulated wire is used, it should be stripped 3/4" at each end before cleaning with emery cloth.
- Attach bronze clamps to pipe. Tighten screws.
- Attach wire to clamps as shown. Tighten screws.

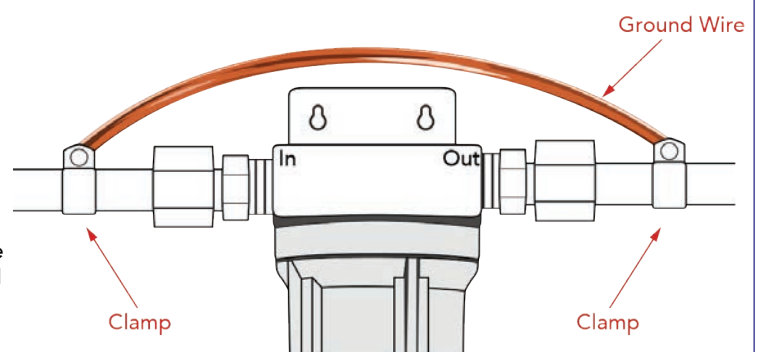



## INSTALLATION ON WHOLE HOUSE MAIN WATER PIPE USING SOLDERED COPPER FITTINGS



Please note all drawings, pictures, colors and sizes are approximate for illustrative purposes only and may not exactly resemble the end product.

NOTE: Be sure to allow a minimum space of 1-1/2" to 2" under the filter for removing the sump.

NOTE: It is recommended that a shut-off valve be placed on both sides of the filter.

NOTE: It is recommended that a Whole House Leak Detector Smart Valve (CQE-WH-03064) be placed directly upstream of your household filter to prevent water damage.

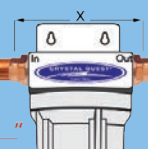
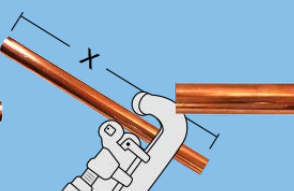
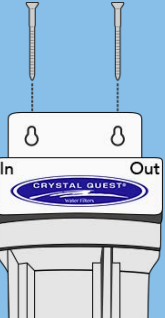
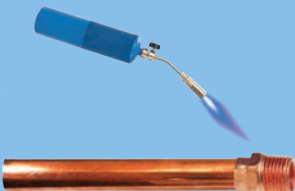
- Minimum Materials Needed
- 2 sweat adapters, 3/4" or 1" NPT x sweat (sweat end to fit existing pipe)
  - Lead-free solder and flux
  - Soldering torch
  - Tubing cutter
  - Thread seal tape
  - Sandpaper or emery cloth
  - open end (to fit sweat adapter) or adjustable jaw wrench

STEP 1 Preparing to Install	STEP 2 Cutting the Pipe	STEP 3 Installing the Mounting Bracket	STEP 4 Attaching Soldered Copper Fittings to Filter Housing
<p><b>CAUTION:</b> Heat created when soldering can damage the water filter housing. Be sure to use the following procedures to protect the water filter.</p> <ul style="list-style-type: none"> <li>• Turn off the water supply and open a nearby faucet to drain the water out of pipes.</li> </ul> <p><b>NOTE:</b> Have a bucket and towel available to collect excess water. Remove the nut and brass ferrule from both compression fittings and set aside. Using a tape measure or ruler, measure the distance "X".* Mark these dimensions so you do not forget.</p> 	<p>Refer to <b>Installing the Ground Wire</b> section before cutting the pipe.</p> <ul style="list-style-type: none"> <li>• Select a secure location surface to install filter and mounting bracket. The location should align the filter system with inlet and outlet pipe and should not cause the pipes to bend or become damaged. Mark the distance "X" on the pipe.</li> <li>• Using a pipe cutter, cut pipe. Sand (file) cut ends of pipe to ensure that they are square and smooth.</li> </ul> 	<ul style="list-style-type: none"> <li>• The bracket can be used as a template for marking the location of the mounting screws.</li> <li>• Use four hex washer-head screws to mount bracket to the wall firmly. Use proper anchors on wall. Anchors are NOT included.</li> </ul> 	<ul style="list-style-type: none"> <li>• Solder a sweat adapter onto one of the pipe ends.</li> </ul>  <ul style="list-style-type: none"> <li>• Place, but do not solder, a straight connector onto the other pipe end.</li> </ul> 

\*Measure to shoulder inside of fittings. Copper pipe butts against this shoulder.

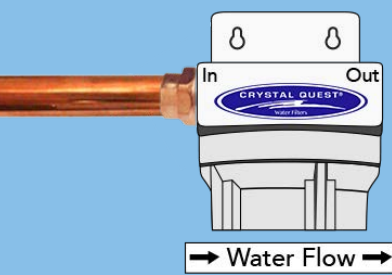
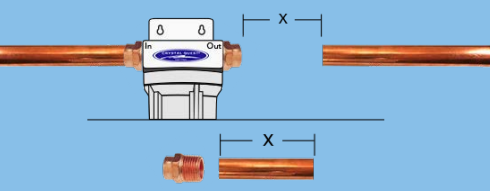
STEP 5 Attaching Soldered Fittings to Filter Head	STEP 6 Installing the Unit	STEP 7 Final Check
<ul style="list-style-type: none"> <li>• Remove the sump from the filter head and set the sump aside.</li> <li>• After the sweat adapter cools, apply several wraps of Teflon® tape to the threads on the sweat adapter fitting.</li> <li>• Carefully turn the filter head INLET (if water flow is from the left) onto the sweat adapter fitting. If water flow is from the right, turn the outlet side of the head onto the fitting. DO NOT cross-thread or overtighten. This will cause damage to the threads and crack the head.</li> </ul> 	<ul style="list-style-type: none"> <li>• Mark the distance of "X" on a length of copper pipe. Cut the length of pipe.</li> <li>• Remove the sweat adapter fitting from the filter head and solder to the cut length of pipe.</li> <li>• After the sweat adapter cools, apply several wraps of Teflon® tape to the threads on the sweat adapter fitting. Apply flux and place the pipe end of the soldered assembly into the straight connector, then turn the adapter end into the filter head and tighten.</li> <li>• Solder both sides of the straight connector.</li> <li>• Before replacing the sump and turning on the water supply, install the filter cartridge. Tighten filter housing to seal (refer to <b>Changing Cartridges</b> section).</li> </ul> 	<ul style="list-style-type: none"> <li>• Install filter if not already done (refer to <b>Changing Cartridges</b> section).</li> <li>• Slowly turn on water supply.</li> <li>• Check entire system for leaks.</li> <li>• If the system leaks from the fittings, shut off the water flow and tighten or reseal the fittings. If the system leaks from the filter housing, tighten the housing with a wrench.</li> <li>• After installation, flush the cartridge for 10 minutes. Wait one hour, then flush again for 10 minutes before use.</li> </ul>

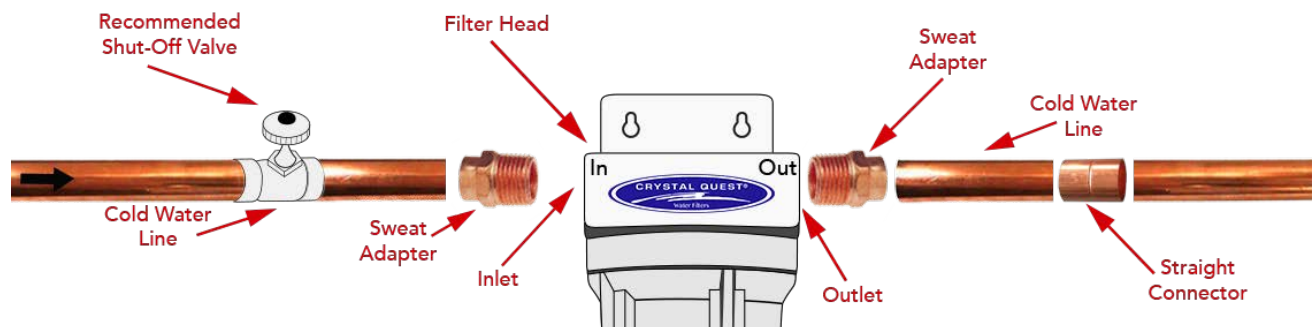



## INSTALLATION ON HOUSE MAIN WATER PIPE USING THREADED PIPE FITTINGS

Please note all drawings, pictures, colors and sizes are approximate for illustrative purposes only and may not exactly resemble the end product.

NOTE: Be sure to allow a minimum space of 1-1/2" to 2" under the filter for removing the sump.

NOTE: It is recommended that a shut-off valve be placed on both sides of the filter.

NOTE: It is recommended that a Whole House Leak Detector Smart Valve (CQE-WH-03064) be placed directly upstream of your household filter to prevent water damage.

### Minimum Materials Needed

- Pipe threading tool
- Pipe wrenches
- Pipe joint compound
- Union fittings and pipe nipples
- Pipe cutter
- Thread seal tape

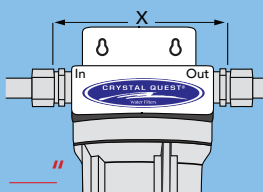
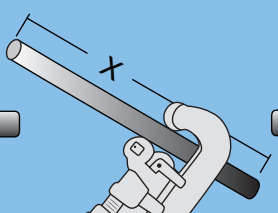
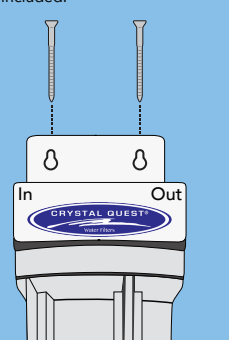
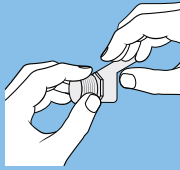
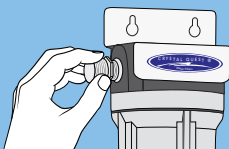
<b>STEP 1</b> Cutting Water Line	<b>STEP 2</b> Cutting the Pipe	<b>STEP 3</b> Installing the Mounting Bracket	<b>STEP 4</b> Attaching Hex Nipple Fittings to Filter Housing
<p><b>CAUTION:</b> Turn off the water supply and open a nearby faucet to drain the water out of pipes.</p> <ul style="list-style-type: none"> <li>• Using a tape measure or ruler, measure the distance "X".</li> </ul> <p><b>NOTE:</b> Have a bucket and towel available to collect excess water. Remove the nut and brass ferrule from both compression fittings and set aside. Using a tape measure or ruler, measure the distance "X". * Mark these dimensions so you do not forget.</p>  <p>X = ___"</p>	<p>Refer to <b>Installing the Ground Wire</b> section before cutting the pipe.</p> <ul style="list-style-type: none"> <li>• Select a secure location surface to install filter and mounting bracket. The location should align the filter system with inlet and outlet pipe and should not cause the pipes to bend or become damaged. Mark the distance "X" on the pipe.</li> <li>• Using a pipe cutter, cut pipe. Sand (file) cut ends of pipe to ensure that they are square and smooth.</li> </ul> 	<ul style="list-style-type: none"> <li>• The bracket can be used as a template for marking the location of the mounting screws.</li> <li>• Use four hex washer-head screws to mount bracket to the wall firmly. Use proper anchors on wall. Anchors are NOT included.</li> </ul> 	<ul style="list-style-type: none"> <li>• Apply several wraps of thread seal tape to the threads of both hex nipple fittings.</li> </ul>  <ul style="list-style-type: none"> <li>• CAREFULLY turn the hex nipple fittings into the water filter head inlet and outlet and tighten. DO NOT cross-thread or overtighten. This will damage the threads and crack the head.</li> </ul> 

\*Measure to shoulder inside of fittings. Galvanized pipe butts against this shoulder.

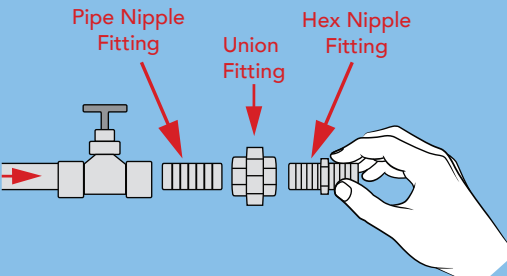
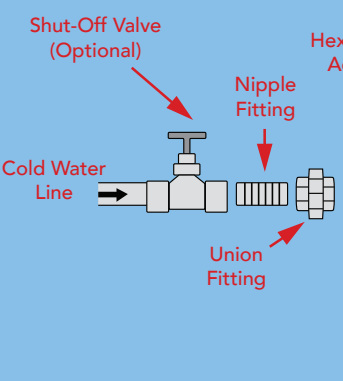
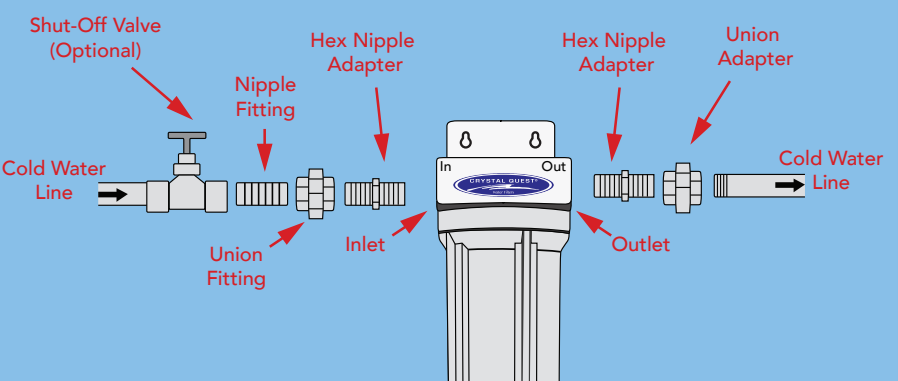
<b>STEP 5</b> Attaching Union Fittings and Pipe Nipple Fittings to Water Line	<b>STEP 6</b> Installing the Unit	<b>STEP 7</b> Final Check
<ul style="list-style-type: none"> <li>• Use pipe joint compound on all external threads.</li> <li>• Do not turn pipe or fittings too tightly into the filter head. This may cause the head to crack.</li> <li>• Fit the pipe nipple into the union fitting, being careful not to cross-thread.</li> <li>• Fit the union and nipple assembly into the shut-off valve.</li> <li>• It is important to have some linear movement in the house main water pipe. This will allow you to tighten union fittings without damaging the filter head if pipe lengths are not exact.</li> </ul> 	<ul style="list-style-type: none"> <li>• Align filter assembly with pipe ends.</li> <li>• With the inlet side of the water filter facing incoming water, spread the pipes apart and fit both hex nipple adapters into the union fitting.</li> <li>• Turn into union fitting and tighten.</li> <li>• Using two adjustable wrenches, hold incoming fitting securely with one wrench and tighten nut with second wrench.</li> <li>• Repeat the procedure on the other side for the outgoing fitting.</li> </ul> 	<ul style="list-style-type: none"> <li>• Slowly turn on water supply.</li> <li>• Check entire system for leaks.</li> <li>• If the system leaks from the fittings, shut off the water flow and tighten or reseal the fittings. If the system leaks from the filter housing, tighten the housing with a wrench.</li> <li>• After installation, flush the cartridge for 10 minutes. Wait one hour, then flush again for 10 minutes before use.</li> </ul> 



## INSTALLATION DIAGRAM OF WHOLE HOUSE COMPACT WATER FILTER SYSTEM

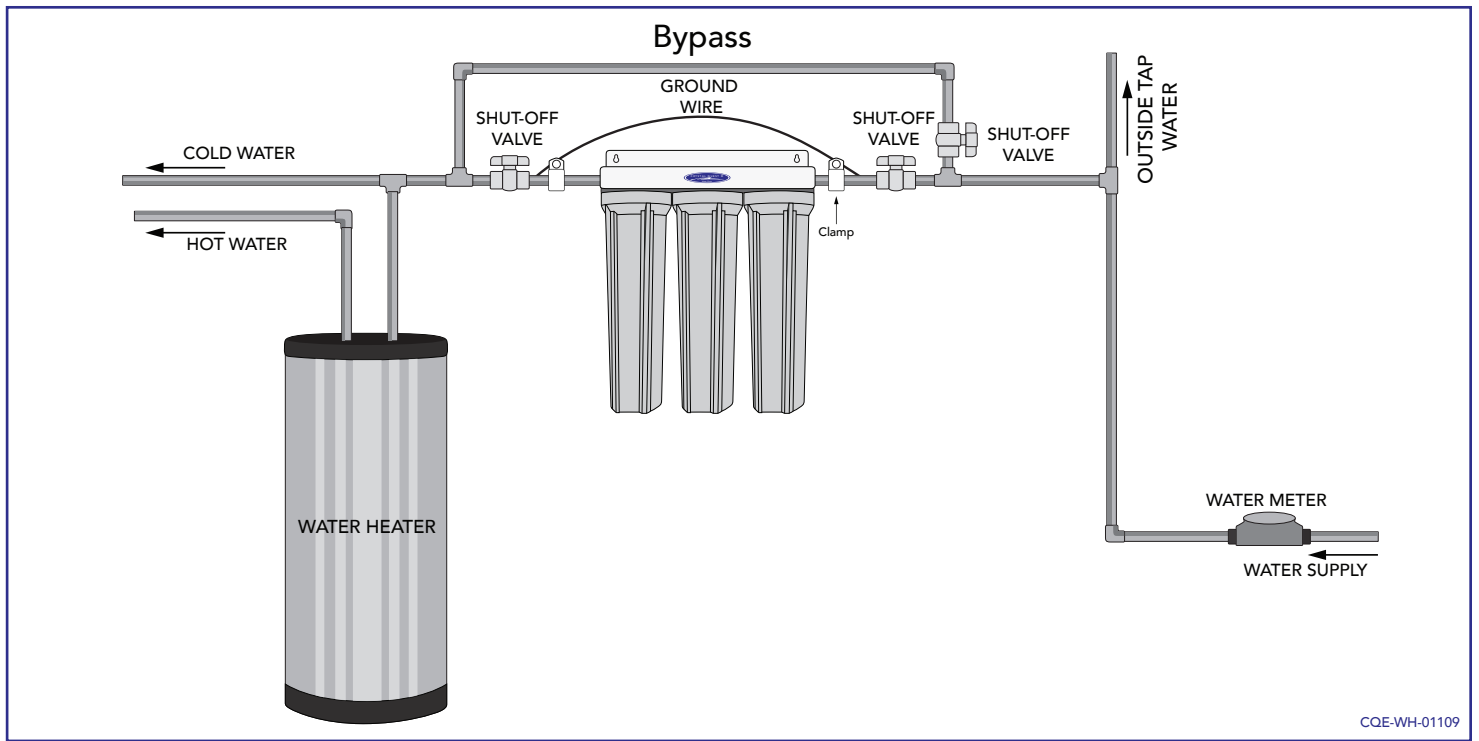

CQE-WH-01109

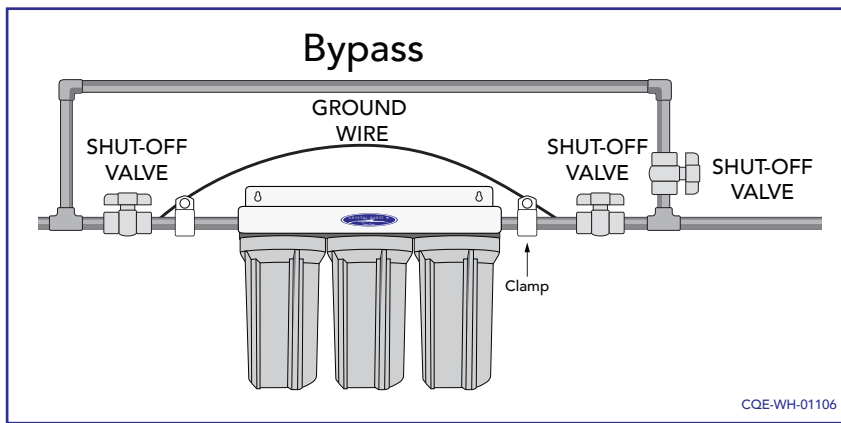

CQE-WH-01106

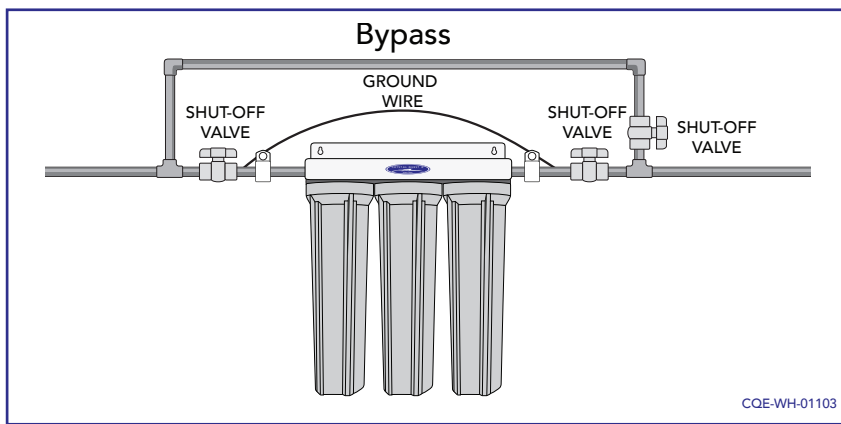

CQE-WH-01103

Please note all drawings, pictures, colors, and sizes are approximate for illustrative purposes only and may not exactly resemble the end product.

### WATER LEAKS

Your system has been tested before leaving the factory. In the unlikely event of a fault, small leaks sometimes do occur as a result of incorrect assembly or abuse. The following tips may be helpful:

- **IMPORTANT: DO NOT CROSS-THREAD OR OVERTIGHTEN.** If cross-threaded, do not put unit into service.
- Depending on the positioning of the filter and the temperature of the incoming water and air, condensation on the outside of the filter housing may occur, resulting in a frosted appearance of fine water droplets on the surface. This does not mean that there is a leak in the system. The remedy is to either insulate the area around the filter or reposition unit.
- Always ensure that sump top is snapped into sump by being pushed in.
- Always ensure that sump ring is screwed fully onto the sump top. This is essential both for the internal seal and the housing seal.
- In the event of a leak, carefully examine its source. Water from a leak may run along the pipe work; it may drip or collect some distance from the actual location of the leak.
- Note: It is recommended that a Whole House Leak Detector Smart Valve (CQE-WH-03064) be placed directly upstream of your household filter to prevent water damage.



## CHANGING CARTRIDGES

You should change your cartridge when the water flow is noticeably reduced or as needed. Depending on the consumption and condition of your water, cartridges may need to be changed more frequently than indicated. Use the time table below as a guide.

- |                       |                    |
|-----------------------|--------------------|
| • Sediment            | every 12 months    |
| • GAC or Carbon Block | every 12 months    |
| • SMART               | every 18-24 months |

### IMPORTANT:

Before first use, run water through cartridge 10 minutes to prepare unit for use. Be sure to allow a minimum space of 1.5"-2" under the filter for removing the housing(s) to change the cartridge(s).

1. Turn off the nearest shut-off valve on the water supply pipe to the filter. Water must be shut off from an upstream valve.
2. Press the red pressure release button to release pressure.
3. Remove the housing using the wrench tool and discard used filter. Wash the filter sump with mild soap and warm water. Do not use harsh cleaners or hot water.
4. Inspect the filter housing O-ring. Make sure it is lightly lubricated with any non-petroleum oil (do not use coconut oil). Be sure the O-ring is completely seated in the groove. The O-ring should be replaced as needed or if it becomes damaged.
5. Place a new cartridge into the sump, making sure it is centered and completely seated on the bottom seal.
6. Reinstall the filter sump to the unit head. Use the sump wrench to tighten. **DO NOT OVERTIGHTEN OR CROSS-THREAD.**
7. Slowly turn on water to the filter by using the upstream shut-off valve.
8. Press the red pressure release button to remove trapped air.
9. After installation, flush the cartridge for 10 minutes. Wait one hour, then flush again for 10 minutes prior to use.

## Parts

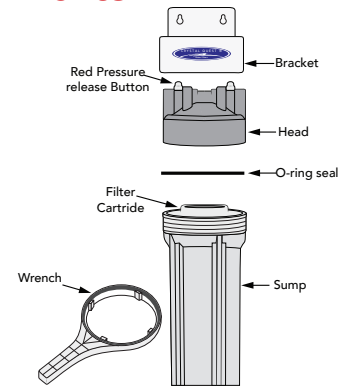

## CARTRIDGE ORIENTATION/ARRANGEMENT

Refer to labels on filter housing(s) for orientation and arrangement of the cartridges. For more information, contact your Crystal Quest® Dealer or technical support at [service@crystalquest.com](mailto:service@crystalquest.com).

## TO ORDER REPLACEMENT CARTRIDGES

Item No. CQE-RC-04014	2-7/8" x 20" 5-Micron Carbon Block Filter Cartridge
Item No. CQE-RC-04015	2-7/8" x 20" 5-Micron Sediment Reusable Pleated Filter Cartridge
Item No. CQE-RC-04016	2-7/8" x 20" Multi Stage PLUS Filter Cartridge
Item No. CQE-RC-04026	2-7/8" x 9-3/4" Compact Whole House Filter Cartridge
Item No. CQE-RC-04027	4-5/8" x 9-3/4" Multi Stage PLUS Filter Cartridge
Item No. CQE-RC-04030	4-5/8" x 20" Multi Stage PLUS Filter Cartridge
Item No. CQE-RC-04033	4-5/8" x 9-3/4" 5-Micron Sediment Reusable Pleated Filter Cartridge
Item No. CQE-RC-04034	4-5/8" x 20" 5-Micron Sediment Reusable Pleated Filter Cartridge
Item No. CQE-RC-04035	4-5/8" x 9-3/4" 5-Micron Carbon Block Filter Cartridge
Item No. CQE-RC-04036	4-5/8" x 20" 5-Micron Carbon Block Filter Cartridge

To order replacement cartridges, contact your Crystal Quest® Dealer or visit us at: [CrystalQuest.com](http://CrystalQuest.com), or call 1-800-934-0051

## COMPACT WHOLE HOUSE WATER FILTER SYSTEMS MODEL NUMBERS

(1) Single Whole House 2.5" x 20"	CQE-WH-01101	Replacement Cartridges: CQE-RC-04016
(2) Double Whole House 2.5" x 20"	CQE-WH-01102	Replacement Cartridges: CQE-RC-04014, CQE-RC-04016
(3) Triple Whole House 2.5" x 20"	CQE-WH-01103	Replacement Cartridges: CQE-RC-04014, CQE-RC-04015, CQE-RC-04016
(4) Single Big Heavy Duty 5" x 10"	CQE-WH-01104	Replacement Cartridges: CQE-RC-04027
(5) Double Big Heavy Duty 5" x 10"	CQE-WH-01105	Replacement Cartridges: CQE-RC-04035, CQE-RC-04027
(6) Triple Big Heavy Duty 5" x 10"	CQE-WH-01106	Replacement Cartridges: CQE-RC-04027, CQE-RC-04033, CQE-RC-04035
(7) Single Big Heavy Duty 5" x 20"	CQE-WH-01107	Replacement Cartridges: CQE-RC-04030
(8) Double Big Heavy Duty 5" x 20"	CQE-WH-01108	Replacement Cartridges: CQE-RC-04036, CQE-RC-04030
(9) Triple Big Heavy Duty 5" x 20"	CQE-WH-01109	Replacement Cartridges: CQE-RC-04030, CQE-RC-04034, CQE-RC-04036
(10) 10" Stainless Steel 2.5" x 10"	CQE-WH-01100	Replacement Cartridges: CQE-RC-04026



## IMPORTANT NOTICE:

All Crystal Quest® water filtration systems should be installed by a qualified, licensed plumber. Not using the service of a licensed plumber will void warranty. Crystal Quest® assumes no liability whatsoever for systems improperly installed or those installed by anyone other than a qualified, licensed plumber.

Plumber's Name

Address

Phone

_____	_____	_____
_____	_____	_____
_____	_____	_____

*(Please record the information above for your future reference.)*

## ONE-YEAR LIMITED WARRANTY

CRYSTAL QUEST® warrants your CRYSTAL QUEST® Whole House Compact System for one year from the date of purchase against all defects in materials and workmanship when used in compliance with the manual. This warranty does not include replacement cartridges unless defective upon receipt. CRYSTAL QUEST® disclaims all implied warranties including, without limitation, warranties of merchantability and fitness for a particular purpose. If for any reason the product proves to be defective within one year from the date of purchase, please call for assistance. This warranty gives you specific legal rights and you may have other legal rights which vary from state to state. CRYSTAL QUEST® assumes no responsibility for incidental or consequential damages, for damages arising out of misuse of the product, or the use of any unauthorized attachment. Some states do not allow the exclusion or limitation of implied warranties or incidental or consequential damages; therefore, the above limitations or exclusions may not apply to you. Should service be required during or after the warranty period or should you have any questions regarding how to use your CRYSTAL QUEST® Whole House Compact System, please contact our Technical Support Department at [service@crystalquest.com](mailto:service@crystalquest.com), Monday through Friday, 9 AM to 5 PM Eastern Time.

## KEEP THIS MANUAL FOR FUTURE REFERENCE AND UNIT MAINTENANCE

Online warranty information  
<http://crystalquest.com/warranty.htm>

Product design is subject to change without notice.

**For further assistance, contact your Crystal Quest dealer  
or visit us at [www.crystalquest.com](http://www.crystalquest.com)**

To view the latest edition of the Whole House Compact System Guide, visit [CrystalQuest.com](http://CrystalQuest.com)





## AUTHORIZED DISTRIBUTOR

Should service be required during or after the warranty period or should you have any questions regarding how to use your Commercial Water Purification System, please contact manufacturer's Technical Support Department Monday through Friday, 9 AM to 5 PM Eastern Time, or your authorized CRYSTAL QUEST dealer:



Mailing Address:

**FilterWater.com**

P.O. Box 968

Southampton, PA 18966

USA

<http://www.FilterWater.com>

Tel. +1 (800) 439-0263

Fax +1 (215) 354-0304

Email: [Sales@filterwater.com](mailto:Sales@filterwater.com)