

MODEL 5600 & 5600 ECONOMINDER®

Service Manual



IMPORTANT: Fill in pertinent information on page 2 for future reference.

MODEL 5600 & 5600 ECONOMINDER®

Job Specification Sheet

- JOB NO. _____
- *MODEL NO. _____
- WATER TEST _____
- CAPACITY PER UNIT _____ MAX. _____ PER REGENERATION
- MINERAL TANK SIZE DIA. _____ HEIGHT _____
- BRINE TANK SIZE & SALT SETTING PER REGENERATION:
- _____

CONTROL VALVE SPECIFICATIONS

Type of Timer

- A) Std C) 7 Day E) Meter, Std.
 B) "L" D) 12 Day F) Meter, Ext.

Day/Time of Regeneration _____

Drain Line Flow Control _____ gpm

Brine Refill Rate _____ gpm

Injector Size _____

Meter Gallon Setting _____ gal.

TYPICAL CONTROL VALVE INFORMATION

Tank Size Dia.	Injector	Slow Rinse Rate (gpm) @ 40 PSI	Brine Draw Rate (SPM) @ 40 PSI	B.L.F.C. ¹	D.L.F.C. ²
6"	# 0 Red	.31 gpm	.28 gpm	.5 gpm	1.2 gpm
7"	# 0 Red	.31 gpm	.28 gpm	.5 gpm	1.2 gpm
8"	# 1 White	.45 gpm	.38 gpm	.5 gpm	1.5 gpm
9"	# 1 White	.45 gpm	.38 gpm	.5 gpm	2.0 gpm
10"	# 1 White	.45 gpm	.38 gpm	.5 gpm	2.4 gpm
12"	# 2 Blue	.84 gpm	.56 gpm	1.0 gpm	3.5 gpm
13"	# 2 Blue	.84 gpm	.56 gpm	1.0 gpm	4.0 gpm
14"	# 3 Yellow	1.0 gpm	.63 gpm	1.0 gpm	5.0 gpm
16"	# 3 Yellow	1.0 gpm	.63 gpm	1.0 gpm	7.0 gpm

Due to varying water conditions, tank sizes and water pressures, the above settings should be used only as a guideline.

¹B.L.F.C. (Brine Line Flow Control). Refill Rate for Filling Brine Tank.

²D.L.F.C. (Drain Line Flow Control). Backwash and Rapid Rinse Flow Rates.

MODEL 5600

Installation and Start-Up Procedure

The water softener should be installed with the inlet, outlet and drain connections made in accordance with manufacturer's recommendations and to meet applicable plumbing codes.

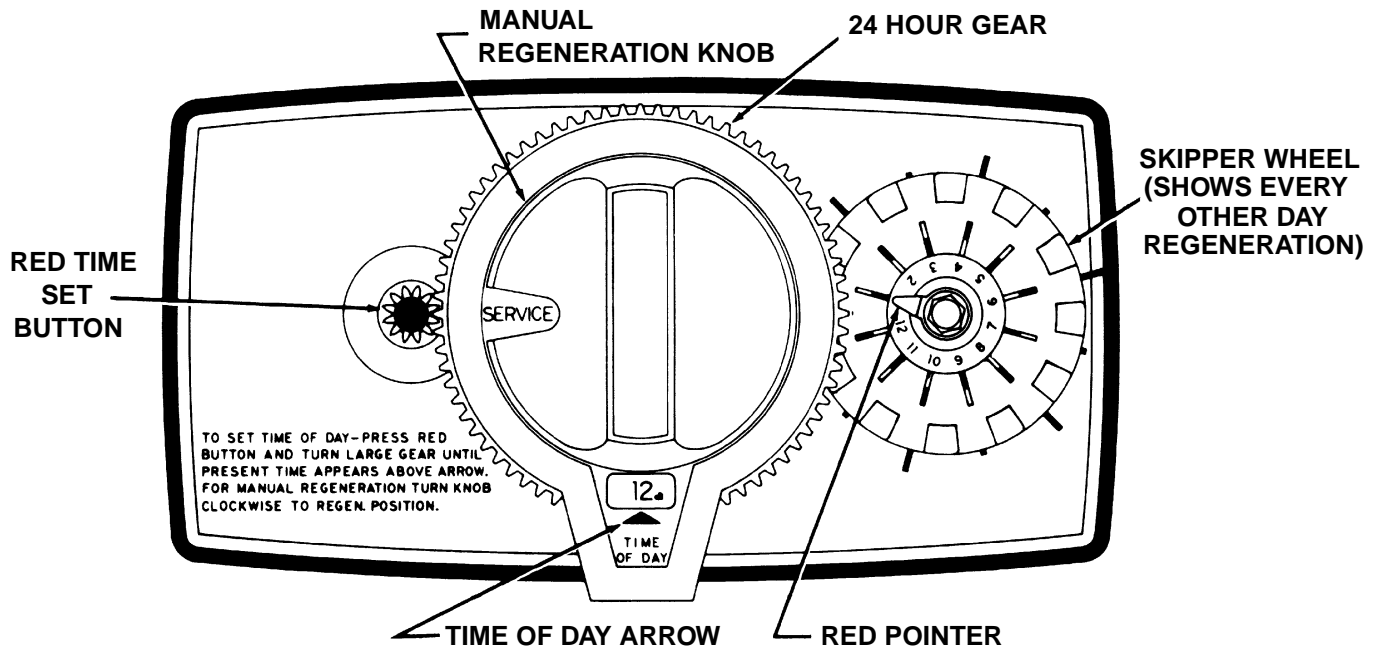

1. Manually index the softener control into the service position and let water flow into the resin tank. When the water flow stops, open a softened water tap until all air is released from the lines, then close the tap.
Note: the various regeneration positions may be dialed manually by turning the knob on the front of the control until the indicator shows that the softener is in the desired position.
2. Manually index the control to the backwash position and allow water to flow at the drain for 3 or 4 minutes.
3. Remove back cover plate.
4. Make sure that the salt dosage is set as recommended by the manufacturer. If necessary, set salt in accordance with the setting instruction sheet. Manually index the control to the brine fill position and allow the brine tank to fill to the top of the air check.
5. Manually index the control to the brine draw position and allow the control to draw water from the brine tank until it stops.
6. Plug in the electrical cord and look in the sight hole in the back of the motor to see that it is running. Set the days that regeneration is to occur by sliding tabs on skipper wheel outward to expose trip fingers. Each tab is one day. Finger at red pointer is tonight. Moving clockwise from red pointer, extend or retract fingers to obtain the desired regeneration schedule.
7. Manually advance the control to the beginning of the brine fill position; and allow the control to return to the service position automatically.
8. Fill the brine tank with salt.
9. Replace back cover on the control.
10. Make sure that any by-pass valving is left in the normal service position.

MODEL 5600

Control Valve Drive Assembly

(See opposite page for parts list)

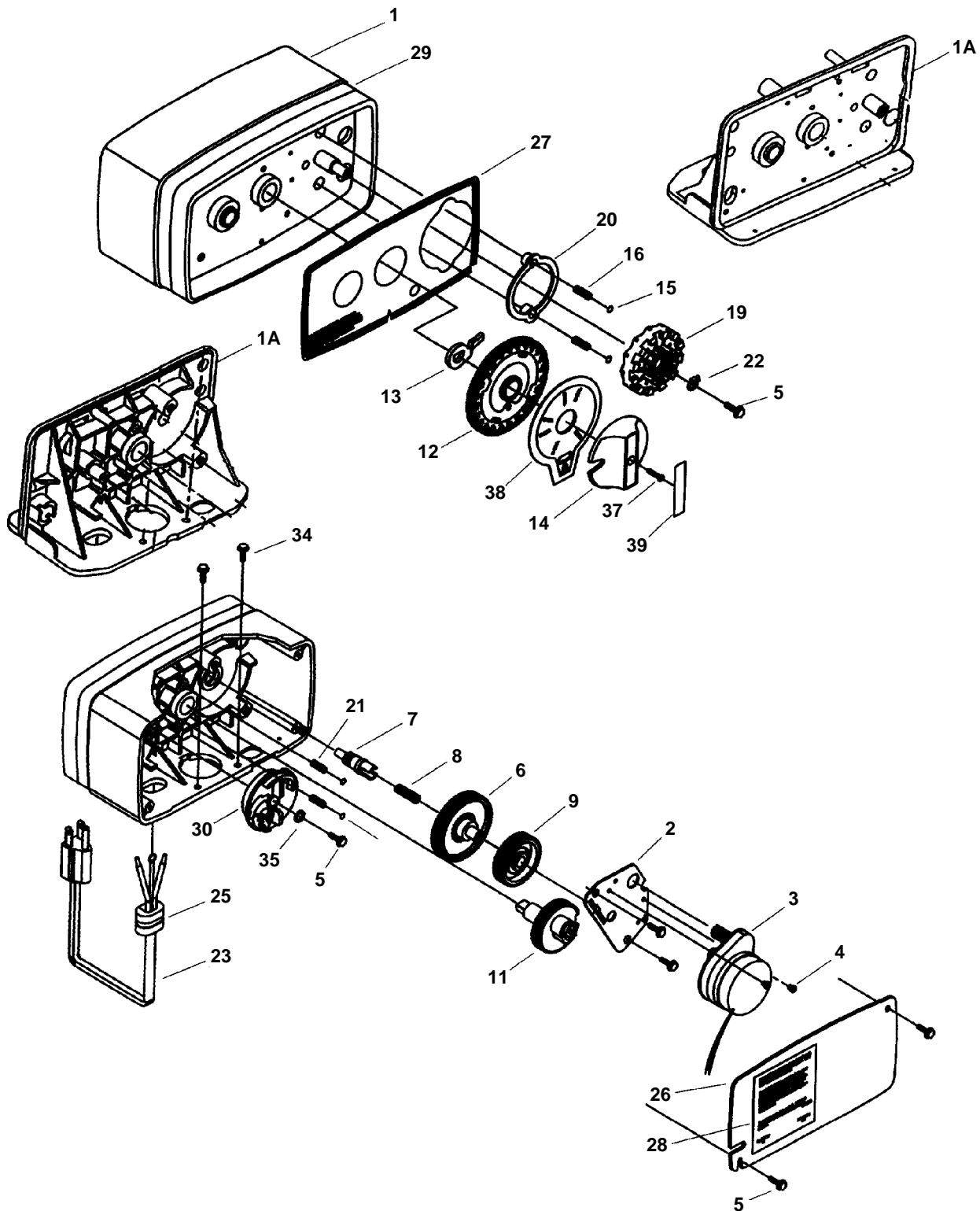

MODEL 5600

Control Valve Drive Assembly

Parts List

Item No.	Quantity	Part No.	Description
1	1	14448-010	Housing - w/Pin
	1	14448-011	Housing - w/Pin Drilled for Screw
	1	14448-012	Housing - w/Pin Drilled for Thumb Screw
1A	1	15494-01	"L" Housing - w/Pin
	1	15494-03	"L" Housing - w/Pin Drilled for Designer
2	1	13175	Motor Mounting Plate
3	1	18743	Motor - 120V., 60 Hz.
	1	19659	Motor - 24V., 60 Hz.
4	(2-3)	11384	Screw - Motor Mtg. & Ground Wire
5	(3-5)	13296	Screw - Component Mounting
6	1	13017	Idler Gear
7	1	13018	Idler Pinion
8	1	13312	Spring - Idler
9	1	13164	Drive Gear
11	1	13170	Main Gear & Shaft
12	1	19205	24 Hour Gear Assembly, Silver
	1	19205-01	24 Hour Gear Assy, Tan
13	1	13011	Cycle Actuator Gear
14	1	14177	Knob - Manual Regeneration
15	4	13300	Ball - 1/4" Dia.
16	2	13311	Spring - Detent - Skipper Wheel
19	1	14381	Skipper Wheel Assembly - 12 Day
	1	14860	Skipper Wheel Assembly - 7 Day
20	1	13864	Skipper Wheel Ring
21	2	14457	Spring - Detent - Main Gear
22	1	13014	Regeneration Pointer
23	1	11842	Electrical Cord - Standard
24	2	12681	Wire Connector (Not Shown)
25	1	13547	Strain Relief
26	1	13229	Back Cover
27	1	13309	Front Label - Brown on Beige
	1	13437	Front Label - Blue/Silver on Black
28	1	13310	Rear Label - Softener
	1	18520	Rear Label - Filter
29	1	13348	Tape Stripe - Brown on Beige
	1	13436	Tape Stripe - Blue on Silver
▲30	1	60514	Brine Cam Assy., 3-18
	1	60514-01	Brine Cam Assy., 6-36
	1	60514-02	Brine Cam Assy. - Minutes
34	2	12473	Screw-Drive Mounting
▲35	1	12037	Washer
37	1	15151	Screw - Knob
38	1	14176	Valve Position Dial - Standard
	1	14278	Valve Position Dial - Low Water
	1	15478	Valve Position Dial - Chemical Filter
	1	16715	Valve Position Dial - Filter
39	1	14175	Knob Label - Beige
	1	14207	Knob Label - Silvers
▲40	1	40214	Screw, Brine Cam

▲Not used when a Filter Valve

MODEL 5600 & 5600 ECONOMINDER®

Control Valve Drive Assembly For (Clock Or Meter)

(See opposite page for parts list)

BACKWASH FILTER INJECTOR OPTION

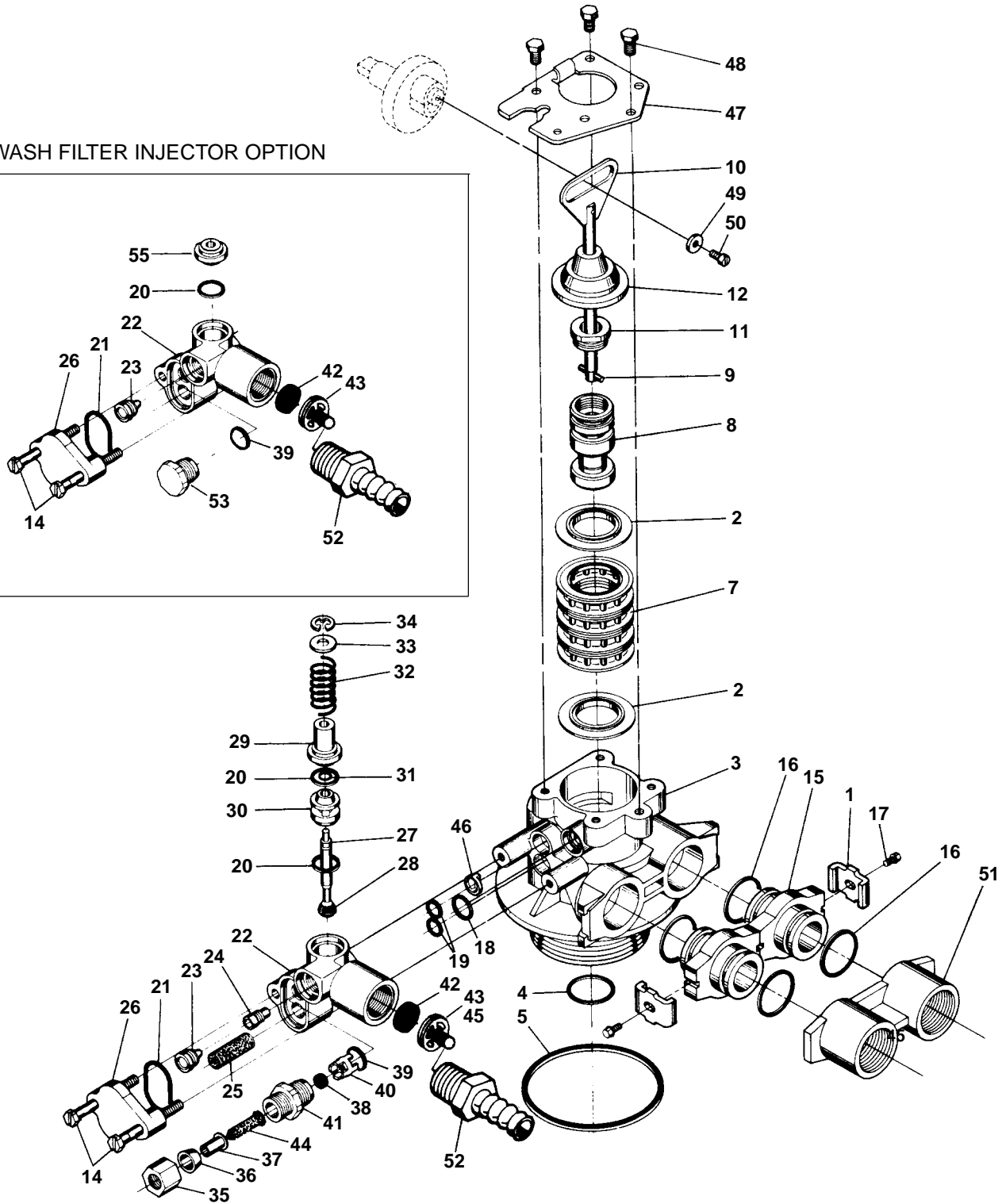
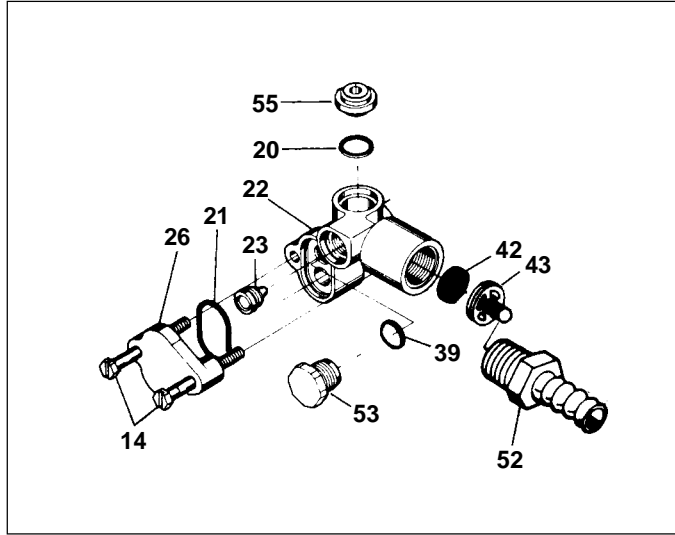

MODEL 5600 & 5600 ECONOMINDER®

Control Valve Drive Assembly For (Clock Or Meter)

Parts List

Item No.	Quantity	Part No.	Description
1	2-4	13255	Adapter Clip (clock or meter)
2	5	13242	Seal
	5	17772	Silicone Seal
3	1	61400-12	Valve Body Assembly - 1" Dist.
	1	61400-11	Valve Body Assembly - 3/4" Dist.
4	1	13304	O-Ring - Distributor Tube - 1"
	1	10244	O-Ring - Distributor Tube - 13/16"
5	1	12281	O-Ring - Top of Tank
6			Not Assigned
7	4	14241	Spacer
8	1	13247	Piston - Standard
	1	13781	Piston - Low Water
	1	13852	Piston - Filter
9	1	10696	Piston Pin
10	1	13001	Piston Rod Assembly
11	1	12953	Piston Retainer
12	1	13446	End Plug Assembly Std. - White
	1	13446-10	End Plug Assembly Filter - Black
	1	13446-20	End Plug Assembly Low Water - Gray
14	2	13315	Screw - Injector Mounting
*15	2	19228	Adapter Coupling
*16	4	13305	O-Ring - Adapter Coupling
*17	2-4	13314	Screw - Adapter Coupling (clock or meter)
18	1	12638	O-Ring - Drain
19	2	13301	O-Ring - Injector
▲20	2	13302	O-Ring - Brine Spacer
21	1	13303	O-Ring - Injector Cover
22	1	13163	Injector Body
▲23	1	10913U	Injector Nozzle - Undrilled
24	1	10914	Injector Throat - Specify Size
25	1	10227	Injector Screen
26	1	13166	Injector Cover
27	1	13172	Brine Valve Stem
28	1	12626	Brine Valve Seat
29	1	13165	Brine Valve Cap
30	1	13167	Brine Valve Spacer
31	1	12550	Quad Ring
32	1	11973	Spring - Brine Valve
33	1	16098	Washer - Brine Valve
34	1	11981-01	Retaining Ring
35	1	10329	B.L.F.C. Fitting Nut
36	1	10330	B.L.F.C. Ferrule
37	1	10332	B.L.F.C. Tube Insert
38	1	12094	B.L.F.C. Button - .25 GPM
	1	12095	B.L.F.C. Button - .5 GPM
	1	12097	B.L.F.C. Button - 1.0 GPM
▲39	1	12977	O-Ring - B.L.F.C.
40	1	13245	B.L.F.C. Button Retainer
41	1	13244	B.L.F.C. Fitting, 3/8"
42	1		D.L.F.C. Button - Specify Size
43	1	13173	D.L.F.C. Button Retainer
44	1	12767	Screen - Brine Line
45	1	15348	O-Ring - D.L.F.C. (not shown)
46	1	13497	Air Disperser
47	1	13546	End Plug Retainer
48	3	12112	Screw
49	1	13363	Washer
50	1	13296	Screw
51A	1	13398	Yoke, Brass, 1" NPT
	1	13708	Yoke, Brass, 3/4" NPT
51B	1	18706	Yoke, Plastic, 1" NPT
	1	18706-02	Yoke, Plastic 3/4" NPT
52	1	13308	Drain Hose Barb
▲53	1	13918	B.L.F.C. - Plug
▲55	1	13857	Brine Valve - Plug

* Not used with meter controls

▲ Note: Used in Backwash Filter

MODEL 5600 BACKWASH FILTER

Installation and Start-Up Procedure

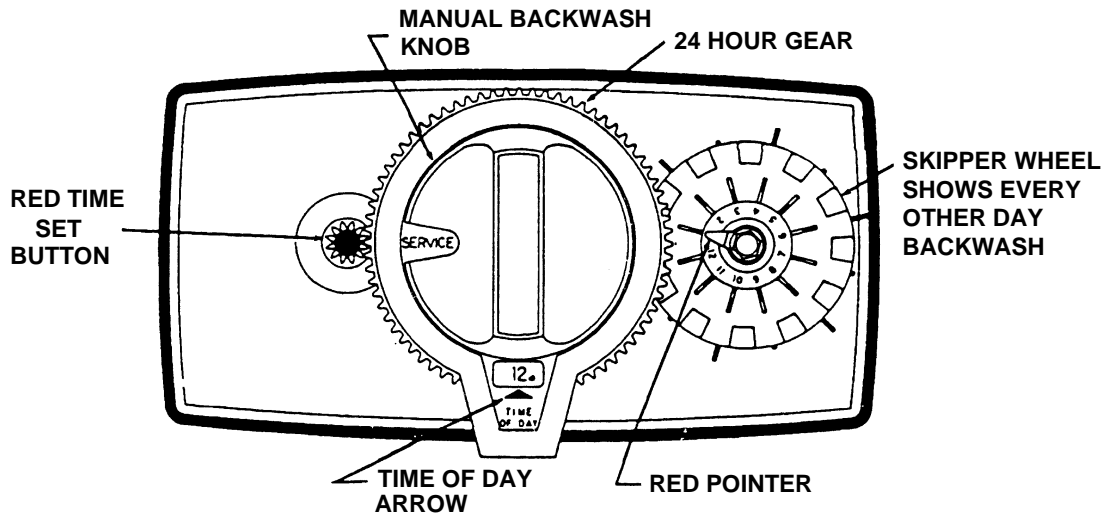

1. The filter should be installed with the inlet, outlet, and drain connections made in accordance with the manufacturer's recommendations and to meet applicable plumbing codes.

BEFORE PLUGGING THE UNIT IN

2. Open a treated water tap down stream of the filter.
3. Manually index the filter to the service position and allow the mineral tank to fill by slowly opening the main water supply valve. (any by pass should be in the service position) NOTE: The water flowing from the down stream tap will be cloudy and/or contain media fines as well as air. Allow water to run until it appears clean and free of air.
4. When a steady clean flow appears at the tap, close the tap and the main water supply valve and allow the filter media bed to settle 15 - 20 minutes.
5. Manually index the filter to the backwash position.
6. To prevent a sudden surge of water and air, partially open the main water supply valve so that the flow at the drain of the filter is approximately 1 gpm. The water at the drain will again be cloudy and/or contain media fines as well as air. Allow water to run until it appears clean and free of air.
7. Continue to open the water supply valve until it is completely open. Allow water to flow at the drain until all media fines are washed out of the filter.
8. Manually index the filter to the service position, and again open the down stream tap. Check to be sure that the water flows clear. If necessary allow water to flow until all media fines are gone. If the tap is equipped with an aerator check that it is not plugged with media fines and pipe scale.
9. Plug in the electrical cord and look in the sight hole on the back of the timer motor to ensure that it is running.

Set the days backwashing is to occur by sliding tabs on the skipper wheel outward to expose trip fingers. Each tab is one day. Finger at red pointer is tonight. Moving clockwise from red pointer, extend or retract fingers to obtain the desired backwash schedule.

10. Set time of day by depressing red button and spin the 24 hr gear until the present time of day is visible above the time of day arrow.

A. CYCLE TIMES & FLOW DIAGRAMS

pages 16-19

(with all following positions, disregard the brine tank, air check and all other items associated with brining)

1. Service Position - same as pictured.
2. Preliminary Rinse Position
 - same as pictured with standard piston (white end plug) or filter piston (black end plug).
 - eliminated with low water piston (gray end plug).
3. Backwash Position
 - same as pictured with standard piston.
 - 15 minutes with filter piston.
 - 7 minutes with low water piston.
- 4 & 5. Brine & Slow Rinse Positions
 - eliminated, resulting in a 50 minute pause, no water flows during this time.
6. Rapid Rinse
 - same as pictured with standard piston.
 - 15 minutes with filter piston.
 - 7 minutes with low water piston.
7. Settling Rinse
 - same as pictured with standard or filter piston.
 - eliminate with low water piston.
8. Brine Tank Refill Position
 - eliminated, filter is back in service at this time.

MODEL 5600 ECONOMIDER®

Installation and Start-up Procedure (Cont'd.)

The water softener should be installed with the inlet, outlet and drain connections made in accordance with manufacturer's recommendations and to meet applicable plumbing codes.

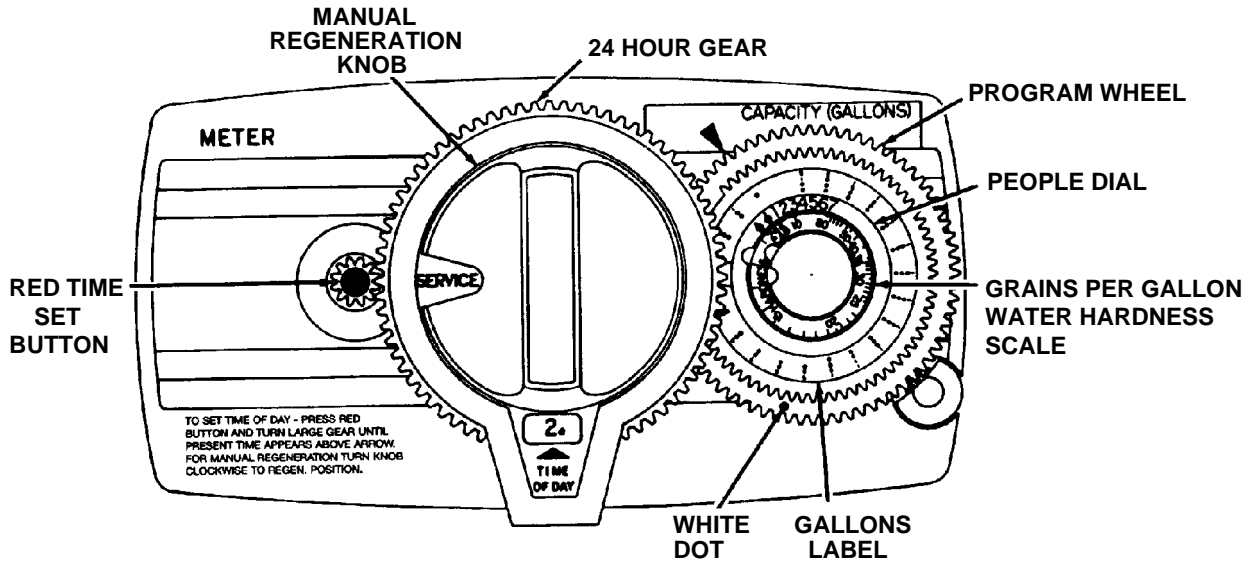

1. Manually index the softener control into the service position and let water flow into the resin tank. When the water flow stops, open a softened water tap until all air is released from the lines, then close the tap.

NOTE: The various regeneration positions may be dialed manually by turning the knob on the front of the control until the indicator shows that the softener is in the desired position.

2. Set water usage program wheel using any one of the following procedures:

Typical Residential Application

To program, just set the time, set the hardness and it automatically monitors system needs and regenerates only when necessary. To set time of day press red time set button and turn 24 hour gear until present time of day is at "time of day". Set program wheel by lifting the "people" dial and rotating it so that the number of people in the household is aligned with the household grains per gallon water hardness. Release the dial and check for firm engagement at setting. (This method will provide reserve capacity based on 75 gallons per person.)

Optional Programming Procedures

Calculate the gallon capacity of the system, subtract the necessary reserve requirement and set the gallons available at the small white dot on program wheel gear. Note, drawing shows 850 gallon setting.

The capacity (gallons) arrow denotes remaining gallons exclusive of fixed reserve.

3. Rotate the program wheel counterclockwise until it stops at regeneration position.
4. Manually index the control to the back-wash position and allow water to flow at the drain for 3 or 4 minutes.
5. Remove back cover plate.
6. Make sure that the salt dosage is set as recommended by the manufacturer. Manually index the control to the brine fill position and allow the brine tank to fill to the top of the air check.
7. Manually index the control to the brine rinse position and allow the control to draw water from the brine tank until it stops.
8. Plug in the electrical cord and look in the sight hole in the back of the monitor to see that it is running.
9. Manually advance the control to the beginning of the brine fill position and allow the control to return to the service position automatically.
10. Fill the brine tank with salt.
11. Replace back cover on the control. Be sure cable is not pinched between cover and housing.
12. Make sure that any by-pass valving is left in the normal service position.

MODEL 5600 ECONOMINDER®

Control Valve Drive Assembly

(See opposite page for parts list)

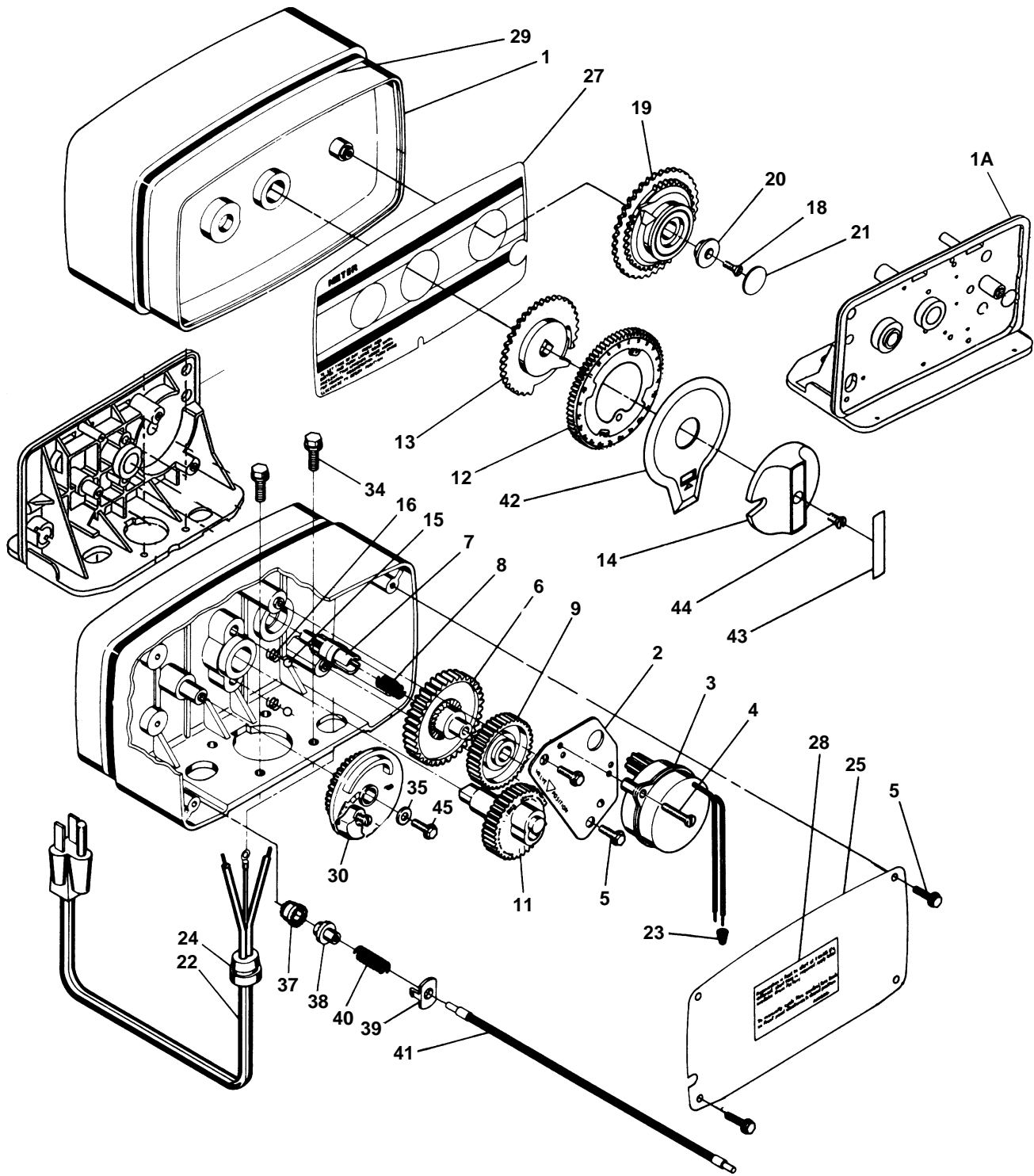

MODEL 5600 ECONOMINDER®

Parts List

Item No.	Quantity	Part No.	Description
1	1	14448-000	Housing - with Roll Pin
	1	14488-001	Housing - w/Pin Drilled for Screw
	1	14448-0	Housing - w/Pin Drilled for Thumb Screw
1A	1	15494-01	"L" Housing - w/Pin
	1	15494-03	"L" Housing - w/Pin Drilled for Designer
2	1	13175	Motor Mounting Plate
3	1	18743	Motor - 120V., 60 Hz.
	1	13494	Motor - 24V., 60 Hz.
4	2-3	11384	Screw - Motor Mtg. & Ground Wire
5	2-4	13296	Screw - Component Mounting
6	1	13017	Idler Gear
7	1	13018	Idler Pinion
8	1	13312	Spring - Idler
9	1	13164	Drive Gear
11	1	13170	Main Gear & Shaft
12	1	19205	24 Hour Gear Assembly, Silver
	1	19205-01	24 Hour Gear Assy, Tan
13	1	13802	Cycle Actuator Gear
14	1	14177	Knob - Manual Regeneration
15	2	13300	Ball - 1/4" Dia.
16	2	14457	Spring - Detent
18	1	13748	Screw - Program Wheel
19	1	60405-15	Program Skipper Wheel Assy. - Specify Hardness Capacity
20	1	13806	Program Wheel Retainer
21	1	13953	Cover Label - Program Wheel
22	1	11842	Electrical Cord
23	2	12681	Wire Connector
24	1	13547	Strain Relief
25	1	13229	Back Cover
26			Not Assigned
27	1	13955	Front Label - Beige
	1	13958	Front Label - Silver
28	1	13310	Rear Label - Softener
	1	18520	Rear Label - Filter
29	1	13957	Tape Stripe - Beige
	1	13960	Tape Stripe - Silver
30	1	60514	Brine Cam Assembly, 3-18
	1	60514-01	Brine Cam Assembly, 6-36
	1	60514-02	Brine Cam Assembly - Minutes
34	2	12473	Screw-Drive Mounting
35	1	12037	Washer
37	1	13830	Drive Pinion - Program Wheel
38	1	13831	Clutch - Drive Pinion
39	1	14253	Spring Retainer
40	1	14276	Spring
41	1	14043	Cable Assembly, Std
	1	14910	Cable Assembly, Ext, Rt Angle
42	1	14176	Valve Position Dial - Standard
	1	14278	Valve Position Dial - Low Water
	1	15478	Valve position Dial - Filter
43	1	14175	Knob Label - Beige
	1	14207	Knob Label - Silver
44	1	15151	Screw - Knob
45	1	40214	Screw, Brine Cam

MODEL 5600 & 5600 ECONOMINDER®

By-Pass Valve Assembly, Plastic

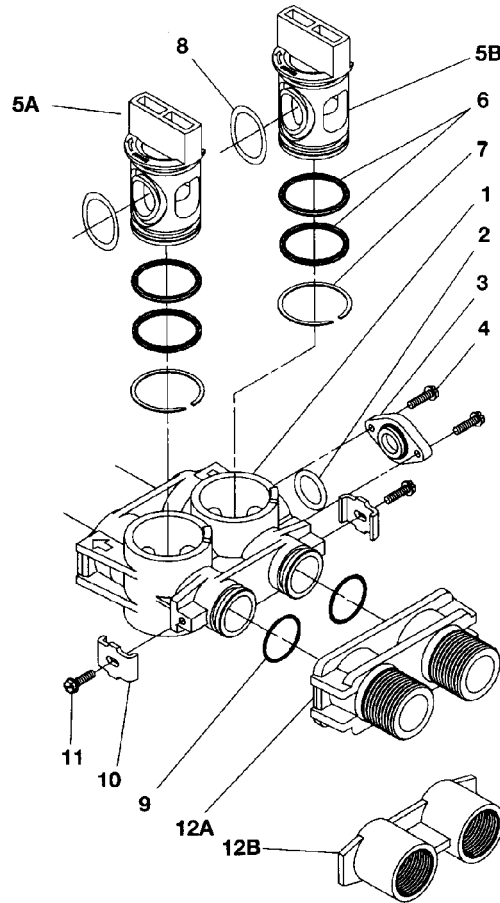

Item No.	Quantity	Part No.	Description
1	1	19723	By-Pass Valve Body, Plastic
2	1	11183	O-Ring, -015
3	1	19724	Cap, By-Pass
4	2	17512	Screw, Hex Washer Head, #6-24 x 3
5A	1	17820	Plug, By-Pass, Inlet
5B	1	17820-01	Plug, By-Pass, Outlet (White)
6	4	18661	O-Ring, -218
7	2	18662	Retaining Ring
8	2	18660	O-Ring
9	2	13305	O-Ring, -119
10	2	13255	Clip, Mounting
11	2	13314	Screw, Hex Washer Head, 8-18 x 5/8
12A	1	18706	Yoke, Plastic, 1" NPT
		18706-02	Yoke, Plastic 3/4"
12B	1	13708	Yoke, 3/4"
	1	13708NP	Yoke, 3/4" Nickel Plated
	1	13398	Yoke, 1"
	1	13398NP	Yoke, 1" Nickel Plated

MODEL 5600 ECONOMINDER®

Meter Assembly

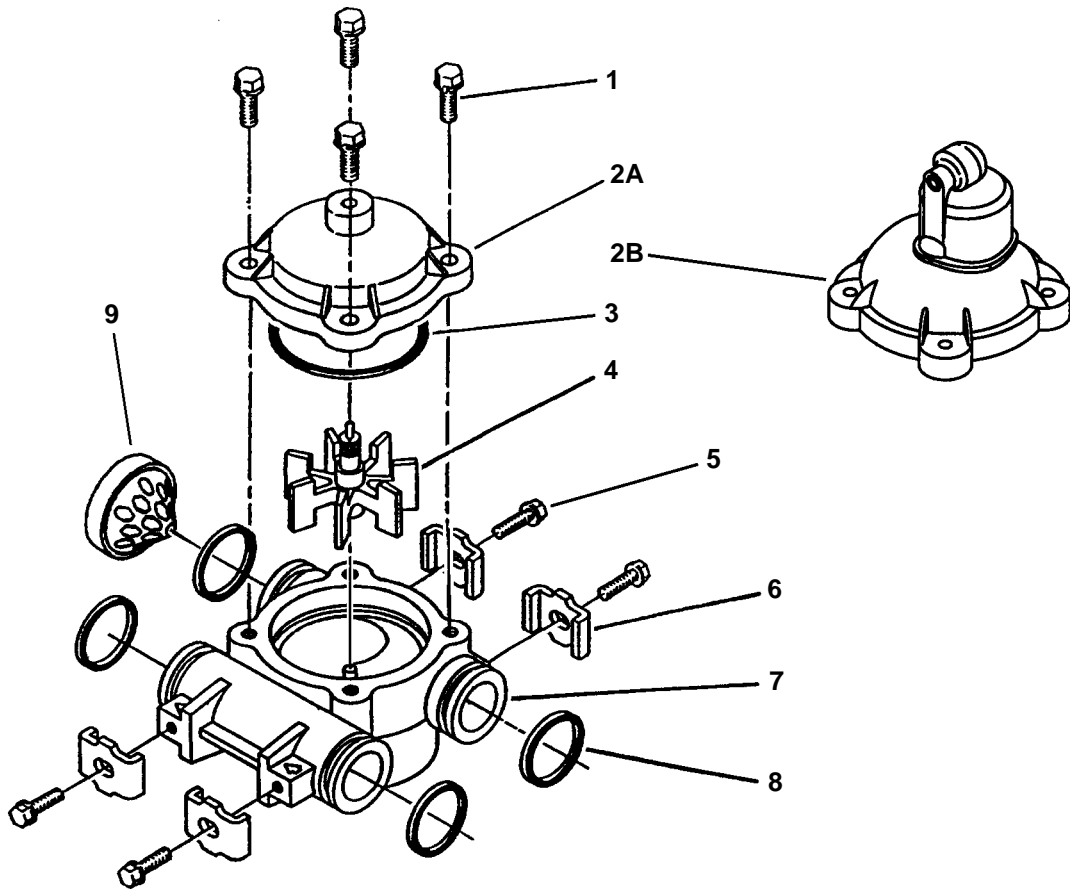

Item No.	Quantity	Part No.	Description
1	4	12473	Screw - Meter Cover Assembly
2A	1	14038	Meter Cover Assembly - Standard
2B	1	15659	Meter Cover Assembly - Extended Range, Rt. Angle
3	1	13847	O-Ring - Meter Cover Assembly
4	1	13509	Impeller
5	4	13314	Screw - Adapter Clip
6	4	13255	Adapter Clip
7	1	13821	Meter Body
8	4	13305	O-Ring - Meter Body
9	1	14613	Flow Straightener

MODEL 5600 & 5600 ECONOMINDER®

By-Pass Valve Assembly

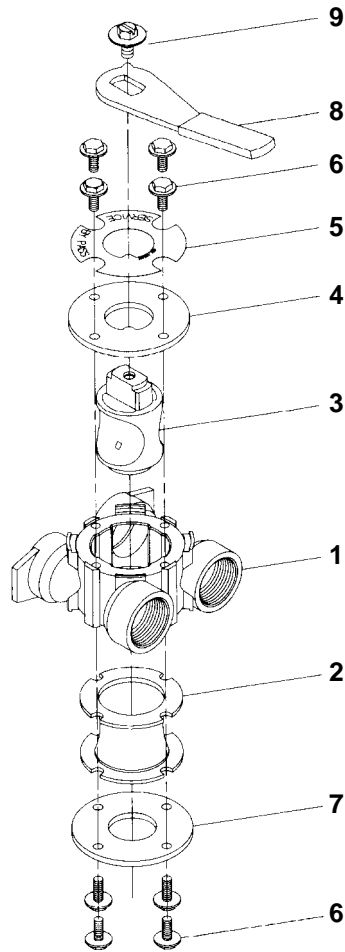

Item No.	Quantity	Part No.	Description
1	1	17290	By-Pass Valve Body, 3/4"
	1	17290NP	By-Pass Valve Body, 3/4" Nickel Plate
	1	13399	By-Pass Valve Body, 1"
	1	13399NP	By-Pass Valve Body, 1" , Nickel Plate
2	1	11726	Seal, By-Pass
3	1	11972	Plug, By-Pass
4	1	11978	Side Cover
5	1	13604-01	Label
6	8	15727	Screw
7	1	11986	Side Cover
8	1	11979	Lever, By-Pass
9	1	11989	Screw, Hex Head, 1/4-14

MODEL 5600 & 5600 ECONOMINDER®

Service Assembly

Parts List

Part No.	Description
60102-00	Piston - Softener
60102-10	Piston - Filter
60102-20	Piston - Low Water
60125	Seal Kit
60084-XX	Injector
60032	Brine Valve
60514	Brine Cam, 3-18
60514-01	Brine Cam, 6-36
60514-02	Brine Cam, Minutes
60510	Coupling with Clip & Screws
60040	Bypass, Brass 3/4" NPT
60041	Bypass, Brass 1" NPT
60049	Bypass, Brass, Plastic
60086	Meter, Std.
60087	Meter, Ext.
60136-5600	Service Kit, Meter
60135-5600	Service Kit, Clock
14860	Skipper Wheel 7 Day
14381	Skipper Wheel 12 Day
60405-10	Meter Program Wheel, Std.
60405-20	Meter Program Wheel, Ext.

MODEL 5600 & 5600 ECONOMINDER®

Water Conditioner Flow Diagrams

1 SERVICE POSITION

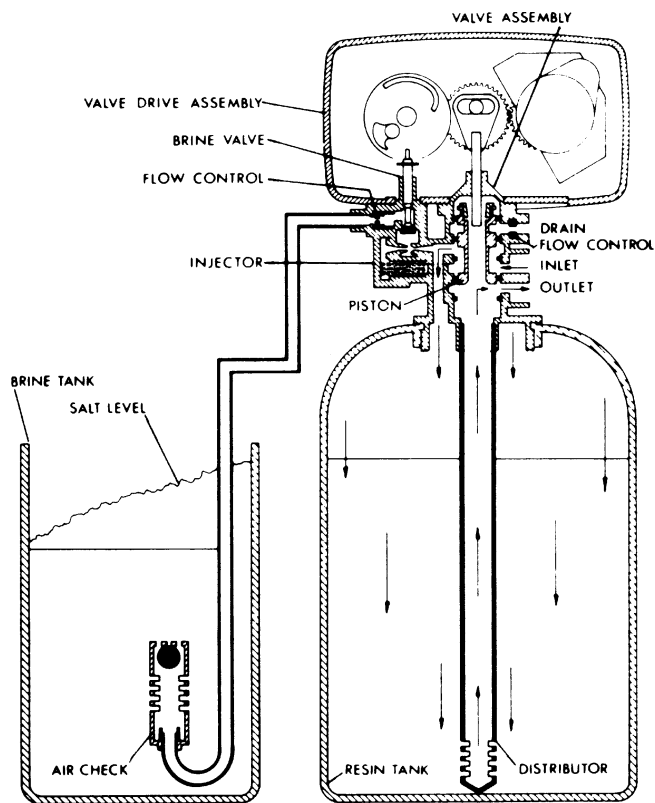

Hard water enters the unit at the valve inlet - flows around the lower piston groove - thru the passage to the top of tank - down thru the resin and enters the distributor as conditioned water. The conditioned water flows up thru the center tube to the valve outlet.

2 PRELIMINARY RINSE POSITION

5 Minutes

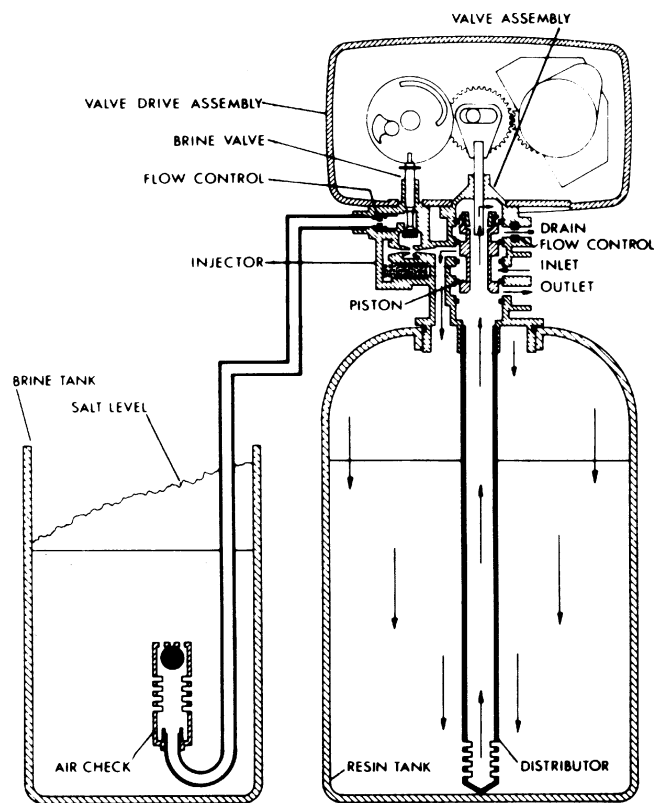

Hard water enters the unit at the valve inlet - flows around the lower piston groove - down thru the top of tank passage - downward thru the resin - up the distributor tube - thru the center hole in the piston - over the top edge of the piston and out the drain line.

MODEL 5600 & 5600 ECONOMINDER®

Water Conditioner Flow Diagrams (Cont'd.)

3 BACKWASH POSITION

10 Minutes

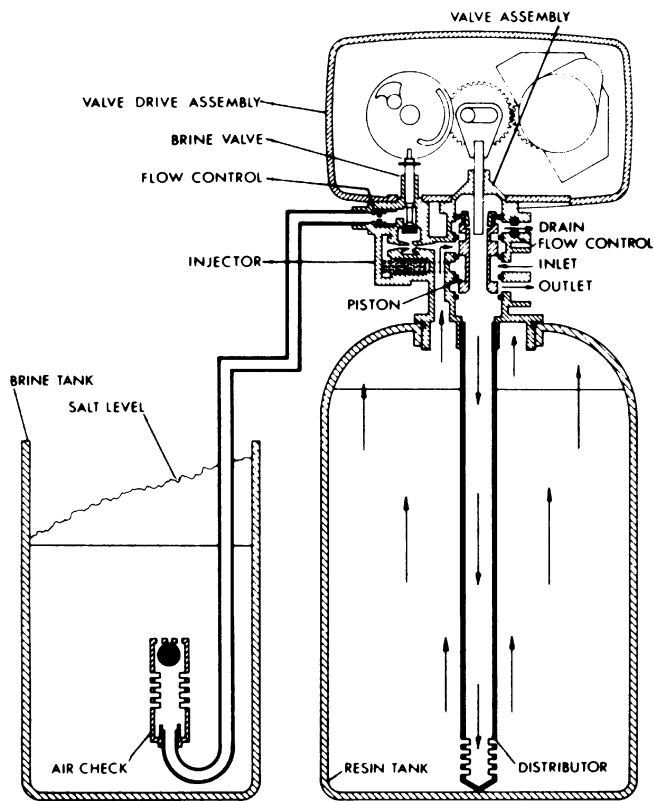

Hard water enters the unit at the valve inlet - flows around the lower piston groove and lower piston land - down thru the center tube and out the distributor - up thru the resin - thru the top of tank passage - around the upper piston groove and out the drain line.

4 BRINE POSITION

First Portion of 50 Minute Fixed Cycle

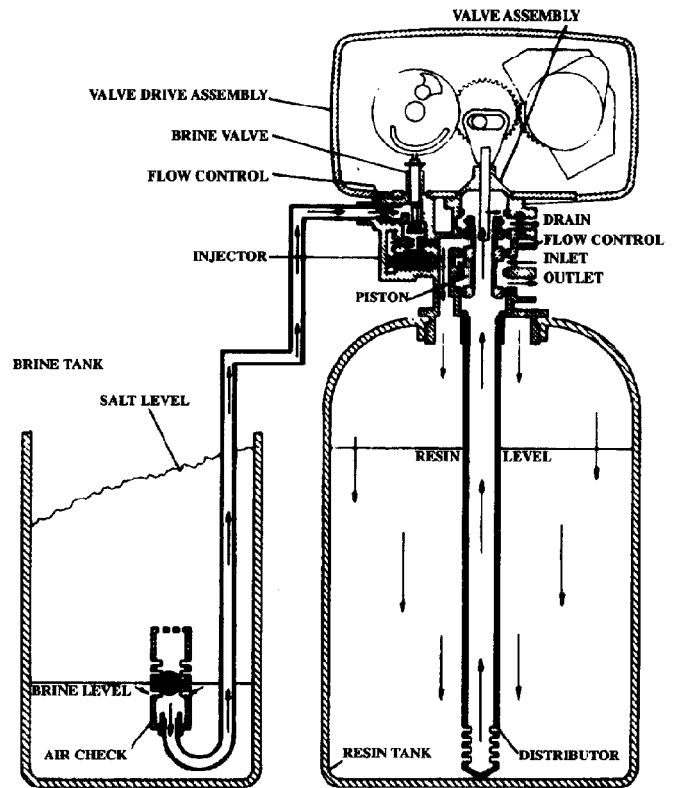

Hard water enters the unit at the valve inlet - flows around the lower piston groove - thru the injector nozzle and orifice to draw brine from the brine tank. The brine flows down thru the resin - into the distributor - up thru the center tube - thru the center hole in the piston and out the drain line.

MODEL 5600 & 5600 ECONOMINDER®

Water Conditioner Flow Diagrams (Cont'd.)

5 SLOW RINSE POSITION

Last Portion of 50 Minute Fixed Cycle

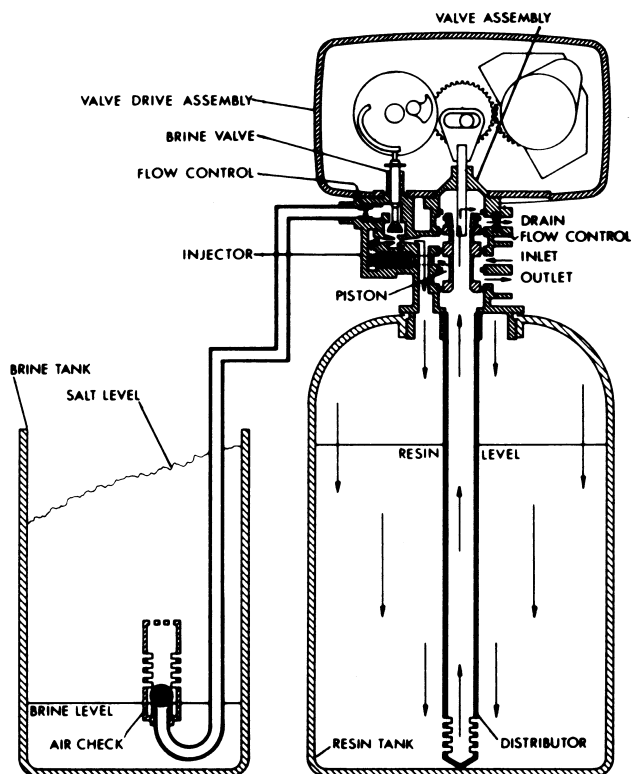

After all the brine has been drawn from the brine tank, hard water continues to enter thru the valve inlet - flows around the lower piston groove - thru the nozzle and orifice - down thru the resin and into the distributor - up thru the center tube - thru the center hole in the piston and out the drain line.

6 RAPID RINSE POSITION

10 Minutes

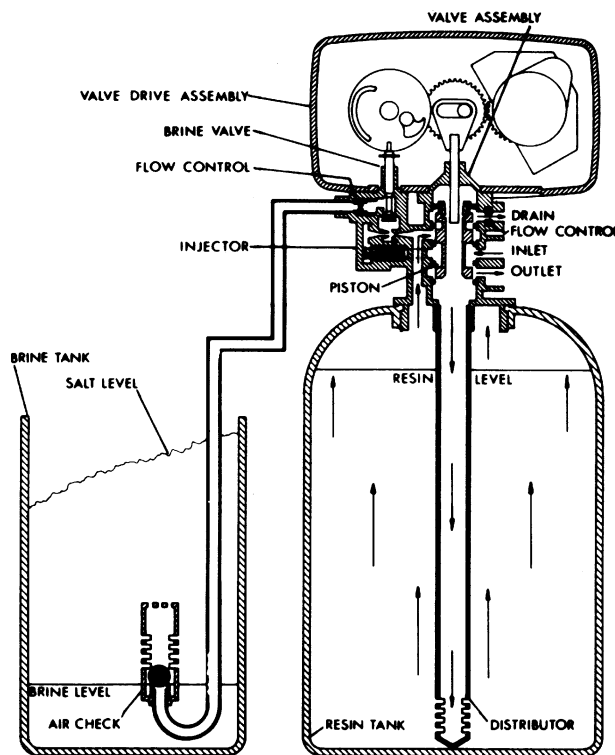

Hard water enters the unit at the valve inlet - flows around the lower piston groove and lower piston land - down thru the center tube and out the distributor - up thru the resin - thru the top of tank passage - around the upper piston groove and out the drain line.

MODEL 5600 & 5600 ECONOMINDER®

Water Conditioner Flow Diagrams (Cont'd.)

7 SETTLING RINSE POSITION

5 Minutes

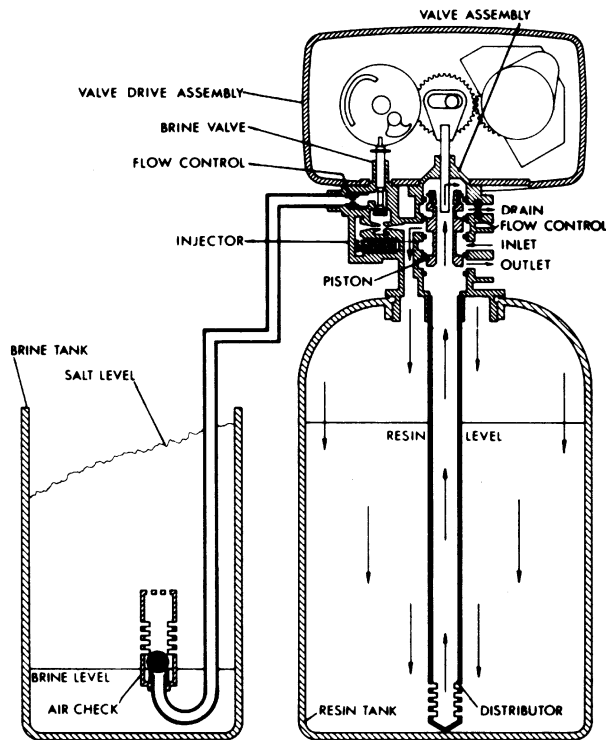

Hard water enters the unit at the valve inlet - flows around the lower piston groove - down thru the top of tank passage - downward thru the resin - up the distributor tube - thru the center hole in the piston - over the top edge of the piston and out the drain line.

8 BRINE TANK FILL POSITION

4 to 24 Minutes Adjustable Cycle

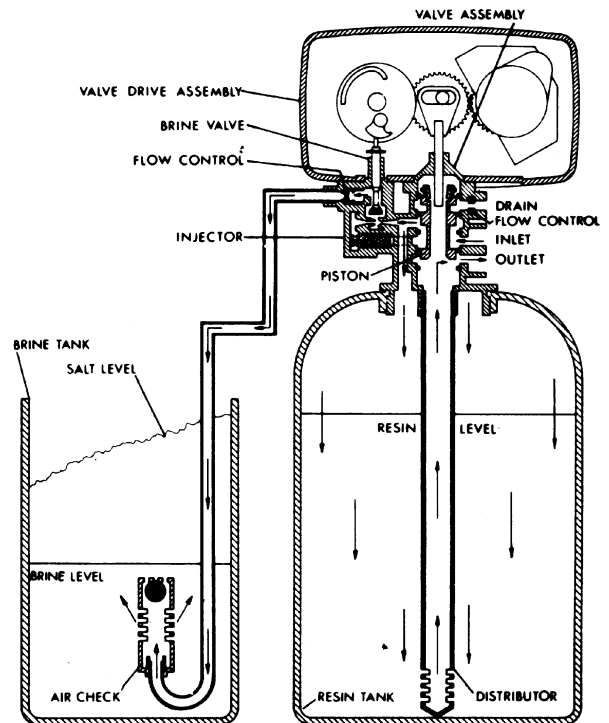

Hard water enters the unit at the valve inlet - flows around the lower piston groove - thru the injector throat - thru the brine valve and flow control to fill the brine tank. Hard water also flows around the lower piston groove - thru the passage to the top of tank - down thru the resin and enters the distributor as conditioned water. The conditioned water flows up thru the center tube to the valve outlet.

MODEL 5600 & 5600 ECONOMINDER®

Trouble-Shooting

PROBLEM	CAUSE	CORRECTION
1. Softener fails to regenerate.	A. Electrical service to unit has been interrupted. B. Timer is defective. C. Power failure.	A. Assure permanent electrical service (check fuse, plug, pull chain or switch). B. Replace timer. C. Reset time of day.
2. Softener delivers hard water.	A. By-pass valve is open. B. No salt in brine tank. C. Injectors or screen plugged. D. Insufficient water flowing into brine tank. E. Hot water tank hardness. F. Leak at distributor tube. G. Internal valve leak.	A. Close by-pass valve. B. Add salt to brine tank and maintain salt level above water level. C. Replace injectors and screen. D. Check brine tank fill time and clean brine line flow control if plugged. E. Repeated flushings of the hot water tank is required. F. Make sure distributor tube is not cracked. Check O-ring and tube pilot. G. Replace seals and spacers and/or piston.
3. Unit uses too much salt.	A. Improper salt setting. B. Excess water in brine tank.	A. Check salt usage and salt setting. B. See problem No. 7.
4. Loss of water pressure.	A. Iron buildup in line to water conditioner. B. Iron buildup in water conditioner. C. Inlet of control plugged due to foreign material broken loose from pipes by recent work done on plumbing system.	A. Clean line to water conditioner. B. Clean control and add resin cleaner to resin bed. Increase frequency of regeneration. C. Remove piston & clean control.
5. Loss of resin through drain line.	A. Air in water system.	A. Assure that well system has proper air eliminator control. Check for dry well condition.
6. Iron In Conditioned Water.	A. Fouled resin bed.	A. Check backwash, brine draw and brine tank fill, increase frequency of regeneration. Increase backwash time.
7a. Excessive water in brine tank.	A. Plugged drain line flow control.	A. Clean flow control.

MODEL 5600 & 5600 ECONOMINDER®

Trouble-Shooting (Cont'd.)

PROBLEM	CAUSE	CORRECTION
8b. Salt water in service line	<ul style="list-style-type: none"> A. Plugged injector system. B. Timer not cycling. C. Foreign material in brine valve. D. Foreign material in brine line flow control. 	<ul style="list-style-type: none"> A. Clean injector and replace screen. B. Replace timer. C. Clean or replace brine valve. D. Clean brine line flow control.
9. Softener fails to draw brine.	<ul style="list-style-type: none"> A. Drain line flow control is plugged. B. Injector is plugged. C. Injector screen plugged. D. Line pressure is too low. E. Internal control leak. 	<ul style="list-style-type: none"> A. Clean drain line flow control. B. Clean or replace injectors. C. Replace screen. D. Increase line pressure. (Line pressure must be at least 20 PSI at all time.) E. Change seals and spacers and/or piston assembly.
10. Control cycles continuous	<ul style="list-style-type: none"> A. Faulty timer mechanism 	<ul style="list-style-type: none"> A. Replace timer.
11. Drain flows continuously.	<ul style="list-style-type: none"> A. Foreign material in control. B. Internal control leak. C. Control valve jammed in brine or backwash position. D. Timer motor stopped or jammed 	<ul style="list-style-type: none"> A. Remove piston assembly and inspect bore, remove foreign material & check control in various regeneration positions. B. Replace seals and/or piston assembly. C. Replace seals and/or piston assembly. D. Replace timer.

General Service Hints For Meter Control

Problem: Softener Delivers Hard Water.

Cause could be that . . . Reserve Capacity Has Been Exceeded.

Correction: Check salt dosage requirements and reset program wheel to provide additional reserve.

Cause could be that . . . Program Wheel Is Not Rotating With Meter Output.

Correction: Pull cable out of meter cover and rotate manually. Program wheel must move without binding and clutch must give positive "clicks" when program wheel strikes regeneration stop. If it does not, replace timer.

Cause could be that . . . Meter Is Not Measuring Flow.

Correction: Check output by observing rotation of small gear on front of timer (Note - program wheel must not be against regeneration stop for this check). Each tooth to tooth is approximately 30 gallons. If not performing properly, replace meter.

MODEL 5600SF

Trouble-Shooting

PROBLEM	CAUSE	CORRECTION
1. Filter fails to backwash.	A. Electrical Service to unit has been interrupted. B. Timer is Defective. C. Power Failure.	A. Assure Permanent Electrical Service (Check Fuse, Plug, Pull Chain or Switch). B. Replace or replace timer. C. Reset time of Day.
2. Filter "bleeds" iron.	A. By-pass valve is open. B. Excessive water usage. C. Hot water tank rusty. D. Leak at distributor tube. E. Defective or stripped filter medium bed. F. Inadequate backwash flow rate.	A. Close by-pass valve. B. Reduce days between, backwashing (see timer instructions.) Make sure that there is not a leaking valve in the toilet bowl or sinks. C. Repeated flushings of the hot water tank is required. D. Make sure distributor tube is not cracked. Check O-ring and tube pilot. E. Replace bed. F. Make sure filter has correct drain flow control. Be sure flow control is not clogged or drain line restricted. Be sure water pressure has not dropped. Increase backwash flow rate according to specifications for your unit. See your dealer for recommendations.
3. Loss of water pressure.	A. Iron or turbidity buildup in water filter. B. Inlet of control plugged due to foreign material broken loose from pipes by recent work done on plumbing system.	A. Reduce days between backwashing so filter backwasher more often. Note: Make sure filter is sized large enough to handle water usage. B. Remove piston and clean control.
4. Loss of filter medium through drain line.	A. Broken or missing top screen.	A. Replace top screen, must have .020" wide slots.
5. Drain flows continuously.	A. Foreign material in control. B. Internal control leak. C. Control valve jammed in rinse or backwash.	A. Remove piston assembly and inspect bore, remove foreign material and check control in various cycle position. B. Replace seals and/or piston assembly. C. Replace piston and seals and spacers. (and drive motor if necessary).

MODEL 5600 & 5600 ECONOMINDER®

Service Instructions

A. TO REMOVE TIME BRINE VALVE, INJECTORS, AND SCREEN

1. Unplug electrical cord from outlet.
2. Turn off water supply to conditioner:
 - a. If the conditioner installation has a “three valve” by-pass system, first open the valve in the by pass line, then close the valves at the conditioner inlet and outlet.
 - b. If the conditioner has an integral by-pass valve, put it in the by-pass position.
 - c. If there is only a shut-off valve near the conditioner inlet, close it.
3. Relieve water pressure in the conditioner by putting the control in the backwash position momentarily. Return the control to the service position.
4. Disconnect brine tube and drain line connections at the injector body.
5. Remove the two injector body mounting screws. The injector and brine module can now be removed from the control valve. Remove and discard valve body O-rings
- 6a. To Replace Brine Valve
 1. Pull brine valve from injector body, also remove & discard O-ring at bottom of brine valve hole.
 0. Apply silicone lubricant to new O-ring and reinstall at bottom of brine valve hole.
 0. Apply silicone lubricant to O- ring on new valve assembly and press into brine valve hole, shoulder on bushing should be flush with injector body.
- 6b. To replace injectors and screen.
 1. Remove injector cap and screen, discard O-ring. Unscrew injector nozzle and throat from injector body.
 0. Screw in new injector throat and nozzle, be sure they are seated tightly. Install a new screen.
 0. Apply silicone lubricant to new “O” ring and install around oval extension on injector cap.
7. Apply silicone lubricant to three new O-rings and install over three bosses on injector body.
8. Insert screws with washers thru injector cap and injector. Place this assembly thru hole in timer housing and into mating holes in the valve body. Tighten screws. (Be sure to reinstall brass spacers with injector on model 4600 valve.)
9. Reconnect brine tube and drain line.
10. Return by-pass or inlef valving to normal service position. Water pressure should now be applied to the conditioner, and any by-pass line shut off.

11. Check for leaks at all seal areas. Check drain seal with the control in the backwash position.
12. Plug electrical cord into outlet.
13. Set time of day and cycle the control valve manually to assure proper function. Make sure the control valve is returned to the service position.
14. Make sure there is enough brine in the brine tank.
15. Rotate program wheel counter-clockwise until it stops at regeneration position
16. Start regeneration cycle manually if water is hard.

B. TO REPLACE TIMER

1. Unplug electrical cord from outlet.
2. Turn off water supply to conditioner:
 - a. If the conditioner installation has a “three valve” by-pass system, first open the valve in the by-pass line, then close the valves at the conditioner inlet and outlet.
 - b. If the conditioner has an integral by-pass valve, put it in the by-pass position.
 - c. If there is only a shut-off valve near the conditioner inlet, close it.
3. Relieve water pressure in the conditioner by putting the control in the backwash position momentarily. Return the control to the service position.
4. Pull cable out of meter cover. Remove the control valve back cover.
5. Remove screw and washer at drive yoke. Remove timer mounting screws. The entire timer assembly will now lift off easily.
6. Put new timer on top of valve. Be sure drive pin on main gear engages slot in drive yoke (rotate control knob if necessary).
7. Replace timer mounting screws. Replace screw and washer at drive yoke.
8. Return by-pass or inlet valving to normal service position. Water pressure should now be applied to the conditioner, and any by-pass line shut off.
9. Plug electrical cord into outlet.
10. Set time of day, program wheel, and salt usage. Cycle the control valve manually to assure proper function. Make sure the control valve is returned to the service position.
11. Replace the control valve back cover. Be sure grommet at cable hole is in place.
12. Make sure there is enough brine in the brine tank.
13. Rotate program wheel counter-clockwise until it stops at regeneration position.
14. Start regeneration cycle manually if water is hard.
15. Plug cable into meter cover, rotate cable to align drive flat if necessary.

MODEL 5600 & 5600 ECONOMINDER®

Service Instructions (Cont'd.)

C. TO REPLACE PISTON ASSEMBLY

1. Unplug electrical cord from outlet.
2. Turn off water supply to conditioner:
 - a. If the conditioner installation has a "three valve" by-pass system, first open the valve in the by-pass line, then close the valves at the conditioner inlet and outlet.
 - b. If the conditioner has an integral by-pass valve, put it in the by-pass position.
 - c. If there is only a shut-off valve near the conditioner inlet, close it.
3. Relieve water pressure in the conditioner by putting the control in the backwash position momentarily. Return the control to the service position.
4. Pull cable out of meter cover. Remove the control valve back cover.
5. Remove screw and washer at drive yoke. Remove timer mounting screws. The entire timer assembly will now lift off easily. Remove end plug retainer plate.
6. Pull upward on end of piston yoke until assembly is out of valve.
7. Inspect the inside of the valve to make sure that all spacers and seals are in place, and that there is no foreign matter that would interfere with the valve operation.
8. Take new piston assembly as furnished and push piston into valve by means of the end plug. Twist yoke carefully in a clockwise direction to properly align it with drive gear. Replace end plug retainer plate.
9. Place timer on top of valve. Be sure drive pin on main gear engages slot in drive yoke (rotate control knob if necessary).
10. Replace timer mounting screws. Replace screw and washer at drive yoke.
11. Return by-pass or inlet valving to normal service position. Water pressure should now be applied to the conditioner, and any by-pass line shut off.
12. Plug electrical cord into outlet.
13. Set time of day. Cycle the control valve manually to assure proper function. Make sure the control valve is returned to the service position.
14. Replace the control valve back cover. Be sure grommet at cable hole is in place.
15. Make sure there is enough brine in the brine tank.
16. Rotate program wheel counter-clockwise until it stops at regeneration position.
17. Start regeneration cycle manually if water is hard.
18. Plug cable into meter cover. Rotate cable to align drive flat if necessary.

D. TO REPLACE SEALS AND SPACERS

1. Unplug electrical cord from outlet.
2. Turn off water supply to conditioner:
 - a. If the conditioner installation has a "three valve" by-pass system, first open the valve in the by-pass line, then close the valves at the conditioner inlet and outlet.
 - b. If the conditioner has an integral by-pass valve, put it in the by-pass position.
 - c. If there is only a shut-off valve near the conditioner inlet, close it.
3. Relieve water pressure in the conditioner by putting the control in the backwash position momentarily. Return the control to the service position.
4. Pull cable out of meter cover. Remove the control valve back cover.
5. Remove screw and washer at drive yoke. Remove timer mounting screws. The entire timer assembly will now lift off easily. Remove end plug retainer plate.
6. Pull upward on end of piston rod yoke until assembly is out of valve. Remove and replace seats and spacers with fingers.

E. TO REPLACE METER

1. Unplug electrical cord from outlet.
2. Turn off water supply to conditioner:
 - a. If the conditioner installation has a "three valve" by-pass system, first open the valve in the by-pass line, then close the valves at the conditioner inlet and outlet.
 - b. If the conditioner has an integral by-pass valve, put it in the by-pass position.
 - c. If there is only a shut-off valve near the conditioner inlet, close it.
3. Relieve water pressure in the conditioner by putting the control in the backwash position momentarily. Return the control to the service position.
4. Pull cable out of meter cover.
5. Remove two screws and clips at by-pass valve or yoke. Pull resin tank away from plumbing Connections.
6. Remove two screws and clips at control valve. Pull meter module out of control valve.
7. Apply silicone lubricant to four new O-rings and assemble to four ports on new meter module.
8. Assemble meter to control valve. Note, meter portion of module must be assembled at valve outlet.
9. Attach two clips and screws at control valve. Be sure clip legs are firmly engaged with lugs.

MODEL 5600 & 5600 ECONOMINDER®

Service Instructions (Cont'd.)

10. Push resin tank back to the plumbing connections and engage meter ports with by-pass valve or yoke.
11. Attach two clips and screws at by-pass valve or yoke. Be sure clip legs are firmly engaged with lugs.
12. Return by-pass or inlet valving to normal service position. Water pressure should now be applied to the conditioner, and any by-pass line shut off.
13. Check for leaks at all seal areas.
14. Plug electrical cord into outlet.
15. Set time of day. Make sure the control valve is in the service position.
16. Rotate program wheel counter-clockwise until it stops at regeneration position.
17. Start regeneration cycle manually if water is hard.
18. Plug cable into meter cover. Rotate cable to align drive flat if necessary.

F. TO REPLACE METER COVER AND/OR IMPELLER

1. Unplug electrical cord from outlet.
 2. Turn off water supply to conditioner:
 - a. If the conditioner installation has a "three valve" by-pass system, first open the valve in the by-pass line, then close the valves at the conditioner inlet and outlet.
 - b. If the conditioner has an integral by-pass valve, put it in the by-pass position.
 - c. If there is only a shut-off valve near the conditioner inlet, close it.
3. Relieve water pressure in the conditioner by putting the control in the backwash position momentarily. Return the control to the service position.
 4. Pull cable out of meter cover.
 5. Remove four screws on cover
 6. Lift cover off of meter module, discard O-ring.
 7. Remove and inspect impeller for gear or spindle damage, replace if necessary.
 8. Apply silicone lubricant to new O-ring and assemble to the smallest diameter on meter cover.
 9. Assemble cover to meter module. Be sure impeller spindle enters freely into cover. Press firmly on cover and rotate if necessary to assist in assembly.
 10. Replace four screws and tighten.
 11. Return by-pass or inlet valving to normal service position. Water pressure should now be applied to the conditioner, and any by-pass line shut off.
 12. Check for leaks at all seal areas.
 13. Plug electrical cord into outlet.
 14. Set time of day. Make sure the control valve is in the service position.
 15. Rotate program wheel counter-clockwise until it stops at regeneration position.
 16. Start regeneration cycle manually if water is hard.
 17. Plug cable into meter cover. Rotate cable to align drive flat if necessary.

Notes
