



# Culligan®

## *Culligan® Commercial Reverse Osmosis Water Systems*

*assisted living facilities*

*cafeterias*

*casinos*

*corporate campuses*

*educational facilities*

*food service*

*grocery*

*hotel/hospitality*

*institutions*

*laundry*

*theme parks*

*vehicle wash*

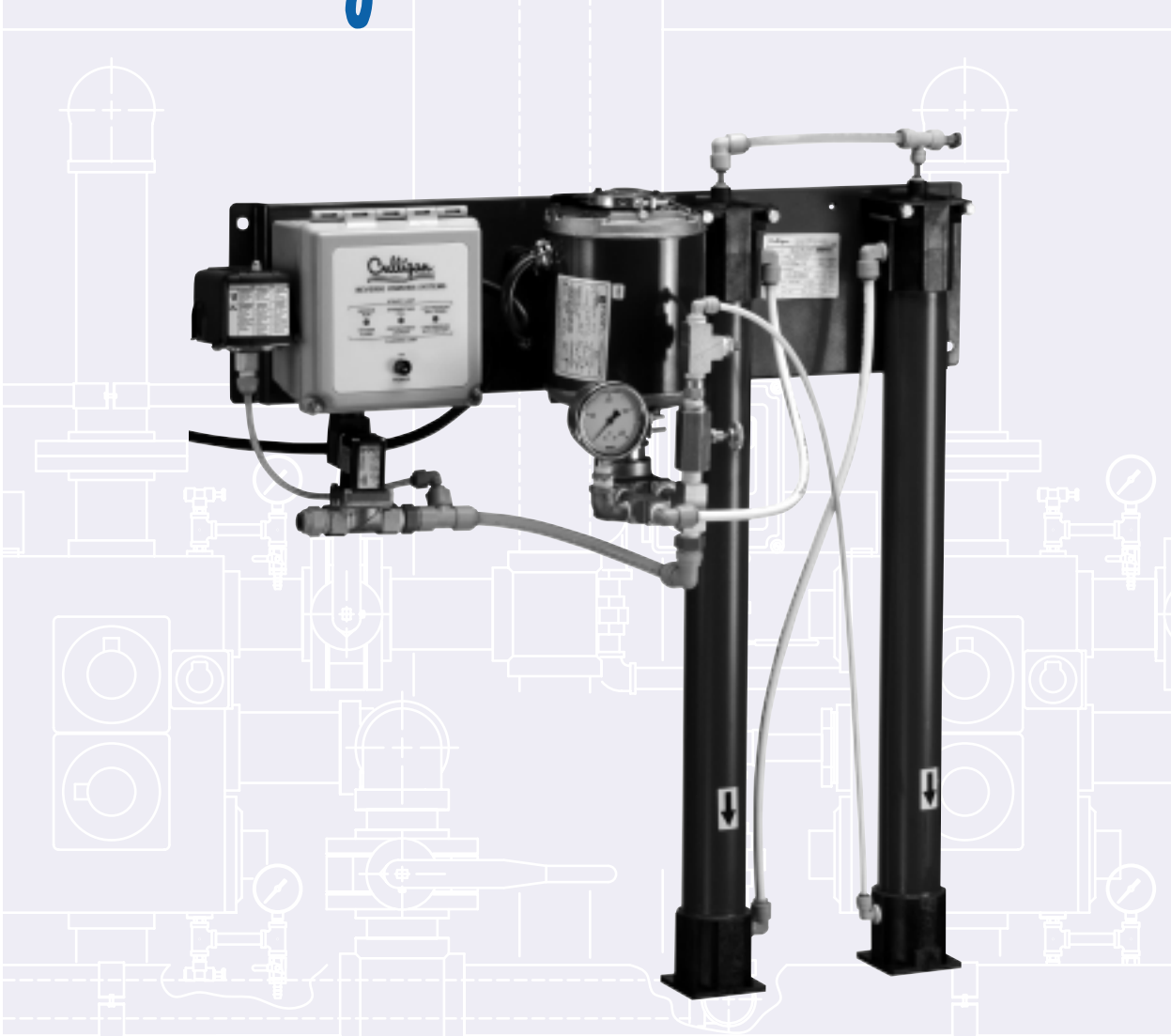

## **Culligan's Series B Reverse Osmosis System**

**The Economical Water Treatment Solution.**

### **Standard Features**

- Thin Film Composite RO Membranes—Rejects significant amounts of dissolved minerals, as well as colloids, particles, organics and silica.\*
- PVC/Noryl Module Housing—Corrosion resistant for long life.
- Positive Displacement Pump & Motor System—Optimum energy efficiency and quiet operation.
- Concentrate Recirculation—Saves water.
- Expandable Design—Grows with your business.
- Cartridge Filtration—Includes a replaceable 5-micron element that removes suspended particles to extend component life. *(not shown)*
- Pressure Indicator—Displays system operating pressure.

\* Do not use with water that is microbiologically unsafe or of unknown quality without adequate disinfection before or after system.

*Trust The Water Experts®*



# Culligan's Series B Reverse Osmosis System

## Applications and Benefits

- Food & Beverage—Superior taste and increased cost savings.
- Ice Production/Drinking Water—Reduces scaling; improves taste and clarity.
- Restaurants—Improves steamer operation.
- Humidification—Reduces scaling and dusting.
- Grocery Stores—Prevents scaling in vegetable misters.
- Pretreatment—For use in deionization systems.
- Boilers—Improves energy efficiency.
- Vehicle Wash—Provides spot-free rinses.

## Series B Plus Standard Features

- Low Pressure Switch—Protects the pump from feed water pressure fluctuations.
- Low Pressure Auto Restart—Minimizes the occurrence of permanent system shut down from low pressure conditions.
- Connection for Pretreatment Signal Switch and Level Control—Allows for easy integration and automatic system operation.
- Auto Flush—Increases membrane life.
- System Indicator Lights—Visually displays system operation or alarm conditions.

## Options

- Product Flow Meter—Displays system performance.
- Pressurized Product Storage Kit—Meets application specifications for bladder storage tanks.
- Wall Mounting Bracket—For easy installation.
- Sturdy Frame Mount Stand—Creates a free standing unit, when wall mounting is not practical.

## System Specifications

Inlet Pressure (dynamic):	20–75 psig 138–515 kPa
Power:	115V/60 Hz/1P
Temperature:	33–100°F
Turbidity, max.:	1 NTU
pH Range:	6–11
Chlorine, max.:	0 mg/L
Total Dissolved Solids, max.:	2500 mg/L
Silt Density Index, max.:	3
Langlier Saturation Index, max.:	0
Iron, max.:	0.1 mg/L
Series B Plus Control Panel:	UL Listed

## Model Descriptions

Model	Nominal Capacity** (GPD)	Approx. Recovery (%)	Motor HP	Approx. Operating Weight (lb)
B-1L	250	25	1/3	45
B-1L Plus				
B-2L	500	50		50
B-2L Plus				
B-3L	750		55	
B-3L Plus				
B-4L	1000	60	1/2	
B-4L Plus				

\*\* Approximate initial capacity based on properly pretreated feed water of 600 ppm TDS as NaCl, 77°F, Silt Density Index below 3, and 225 psi applied pressure supplying water to atmosphere. Productivity will vary depending on the feed water conditions.

“Hey Culligan Man!”

**Culligan**  
Trust the Water Experts.

www.culligan.com™

1-800-CULLIGAN  
© 2003 Culligan International Co.  
Printed in USA (08/03)  
MOORE PART NO. 46907



# Series B and B Plus

## Reverse Osmosis Systems

### Specifications and Operating Data

Models	Nominal Capacity <sup>1</sup>	Module Qty & Size	Approx. Recovery <sup>2</sup>	Motor <sup>3</sup>	Power Req'd	Pipe Size			Dimensions			Approx. Ship. Weight
						Feed (Tube)	Product (Tube)	Waste (Tube)	Width	Depth	Height	
						gpd	in.	%	HP	VAC	in.	
L/day	mm	%	KW	VAC	in.	in.	in.	cm	cm	cm	kg	
<b>B-1L</b>	250	1, 2 x 26	25	1/3	115V/60/1	1/2	3/8	1/4	31	12	32	47
	946.3	1, 51 x 660	25	0.25	115V/60/1	1/2	3/8	1/4	79	30	81	21
<b>B-2L</b>	500	2, 2 x 26	50	1/3	115V/60/1	1/2	3/8	1/4	31	12	32	50
	1892.5	2, 51 x 660	50	0.25	115V/60/1	1/2	3/8	1/4	79	30	81	23
<b>B-3L</b>	750	3, 2 x 26	50	1/3	115V/60/1	1/2	3/8	1/4	31	12	32	55
	2838.8	3, 51 x 660	50	0.25	115V/60/1	1/2	3/8	1/4	79	30	81	25
<b>B-4L</b>	1000	4, 2 x 26	50	1/2	115V/60/1	1/2	3/8	1/4	31	12	32	60
	3785	4, 51 x 660	50	0.37	115V/60/1	1/2	3/8	1/4	79	30	81	27

<sup>1</sup> Nominal initial capacity based on properly pretreated feed water of 600 ppm TDS, temperature of 77° F (25° C), Silt Density Index below 3.0 and an applied pressure of 225 psi. Productivity will vary depending on other feed water conditions.

<sup>2</sup> Depending on feed water quality, it may be possible to operate any unit at a higher recovery to reduce operating costs.

<sup>3</sup> Optional booster pump available.

NOTE: Operational, maintenance and replacement requirements are essential for this product to perform as advertised.

*Culligan*

Commercial Systems  
 ©2004 Culligan 5/04  
 1-800-Culligan  
 www.culligan.com





# LIMITED WARRANTY

## COMMERCIAL/INDUSTRIAL REVERSE OSMOSIS SYSTEMS

You have just purchased one of the finest reverse osmosis water conditioning units made. As an expression of our confidence in Culligan products, your reverse osmosis water conditioning unit is warranted to the original end-user, when installed in accordance with Culligan International Company specifications, against defects in material and workmanship from the date of original installation, as follows:

**For a period of ONE YEAR** { **The entire reverse osmosis conditioning unit, including the reverse osmosis modules, but excluding the expendable filter cartridges used in this unit.**

If a part described above becomes defective, within the specified period, you should notify your independently operated Culligan dealer and arrange a time during normal business hours for the dealer to inspect the reverse osmosis unit on your premises. Any part found defective within the terms of this warranty will be repaired or replaced by the dealer. You pay only freight from our factory and local dealer charges.

Of course, damage caused by accident, fire, flood, freezing, Act of God, misuse, misapplication, neglect, alteration, installation or operation contrary to our printed instructions, or by the use of accessories or components which do not meet Culligan specifications, is not covered by this warranty.

Our product performance specifications are furnished with each water conditioning unit. TO THE EXTENT PERMITTED BY LAW, CULLIGAN DISCLAIMS ALL IMPLIED WARRANTIES INCLUDING, WITHOUT LIMITATION, WARRANTIES OF MERCHANTABILITY AND FITNESS FOR PARTICULAR PURPOSE; TO THE EXTENT REQUIRED BY LAW, ANY SUCH IMPLIED WARRANTIES ARE LIMITED IN DURATION TO THE ONE-YEAR PERIOD SPECIFIED ABOVE FOR THE PARTS DESCRIBED IN THIS LIMITED WARRANTY. As manufacturer, we do not know the characteristics of your water supply or the purpose for which you are purchasing a water conditioner. Please understand that the quality of water supplies may vary seasonally or over a period of time, and that your water usage rate may vary as well. Water characteristics can also change considerably if your water conditioner is moved to a new location. For these reasons, we assume no liability for the determination of the proper equipment necessary to meet your requirements, and we do not authorize others to assume such obligations for us. Further, we assume no liability and extend no warranties, express or implied, for the use of this product on a non-potable water source. OUR OBLIGATIONS UNDER THIS WARRANTY ARE LIMITED TO THE REPAIR OR REPLACEMENT OF THE FAILED PARTS OF THE WATER CONDITIONER, AND WE ASSUME NO LIABILITY WHATSOEVER FOR DIRECT, INCIDENTAL, CONSEQUENTIAL, SPECIAL, GENERAL, OR OTHER DAMAGES, WHETHER FROM CORROSION OR OTHER CAUSES.

### CONSUMERS:

Some states do not allow limitations on how long an implied warranty lasts, so the above limitation may not apply to you. Similarly, some states do not allow the exclusion of incidental or consequential damages, so the above limitation or exclusion may not apply to you. This warranty gives you specific legal rights, and you may also have other rights which vary from state to state. Consult your telephone directory for your local independently-operated Culligan dealer, or write Culligan International Company, for warranty and service information.

**CULLIGAN INTERNATIONAL COMPANY  
One Culligan Parkway  
Northbrook, Illinois 60062**

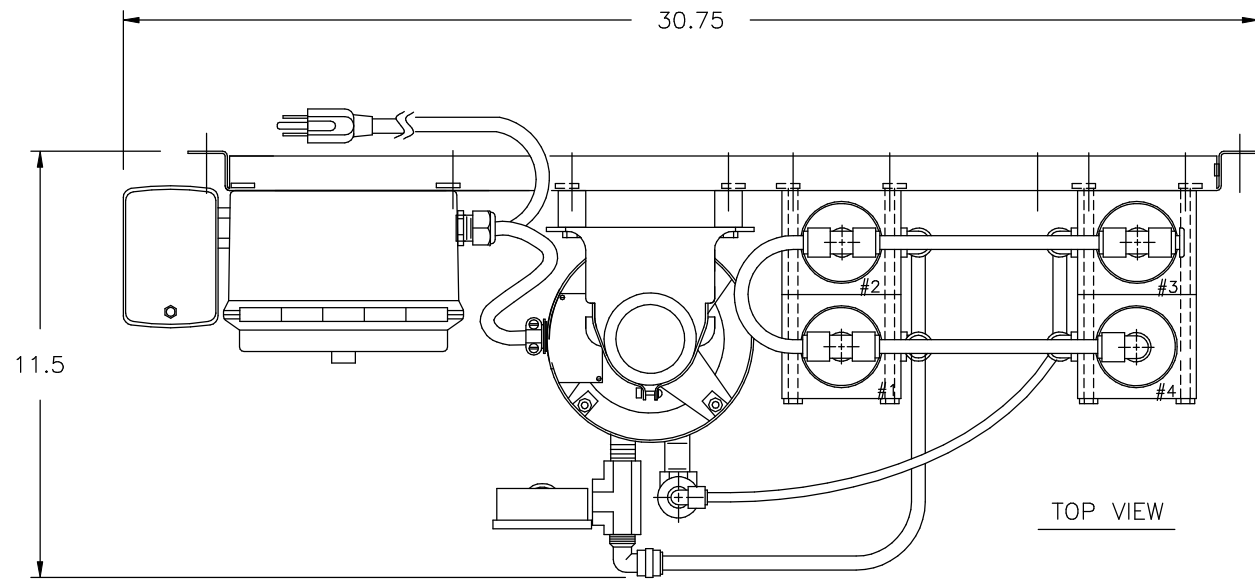

TOP VIEW

NOTES:

- (1) ALL DIMENSIONS ARE GIVEN IN INCHES AND ARE APPROXIMATE.
- (2) A PREFILTER IS PROVIDED AS PART OF THE UNIT. THE INSTALLER MAY WALL MOUNT THE 4 1/2" DIAMETER X 12" LONG PREFILTER TO ANY CONVENIENT LOCATION. THE PREFILTER HAS 1/2" TUBE CONNECTIONS. PLASTIC 1/2" TUBING CONNECTS THE OUTLET OF THE PREFILTER TO THE FEED WATER INLET OF THE SERIES B UNIT. THE RO INLET WATER CONNECTION IS 1/2" TUBING.
- (3) THE PRODUCT WATER CONNECTION IS 3/8" TUBING.
- (4) THE CONCENTRATE WATER CONNECTION IS 1/8" TUBING (EXCEPT B-4L IS 3/16")
- (5) AN OPTIONAL BRACKET FOR WALL MOUNTING ON 16", 18" OR 20" CENTERS IS AVAILABLE. THE WALL MUST BE CAPABLE OF SUPPORTING AT LEAST 60 POUNDS.
- (6) PROVIDE A DRAIN CAPABLE OF HANDLING AT LEAST 1.1 GALLONS PER MINUTE. DO NOT MAKE A DIRECT CONNECTION TO THE DRAIN. PROVIDE AN AIR GAP OF AT LEAST FOUR TIMES THE DIAMETER OF THE DRAIN PIPE TO CONFORM TO SANITATION CODES AND TO PERMIT THE OBSERVATION OF THE DRAIN FLOW. DO NOT INSTALL A VALVE IN DRAIN LINE.
- (7) THE POWER CORD IS 8 FEET LONG.

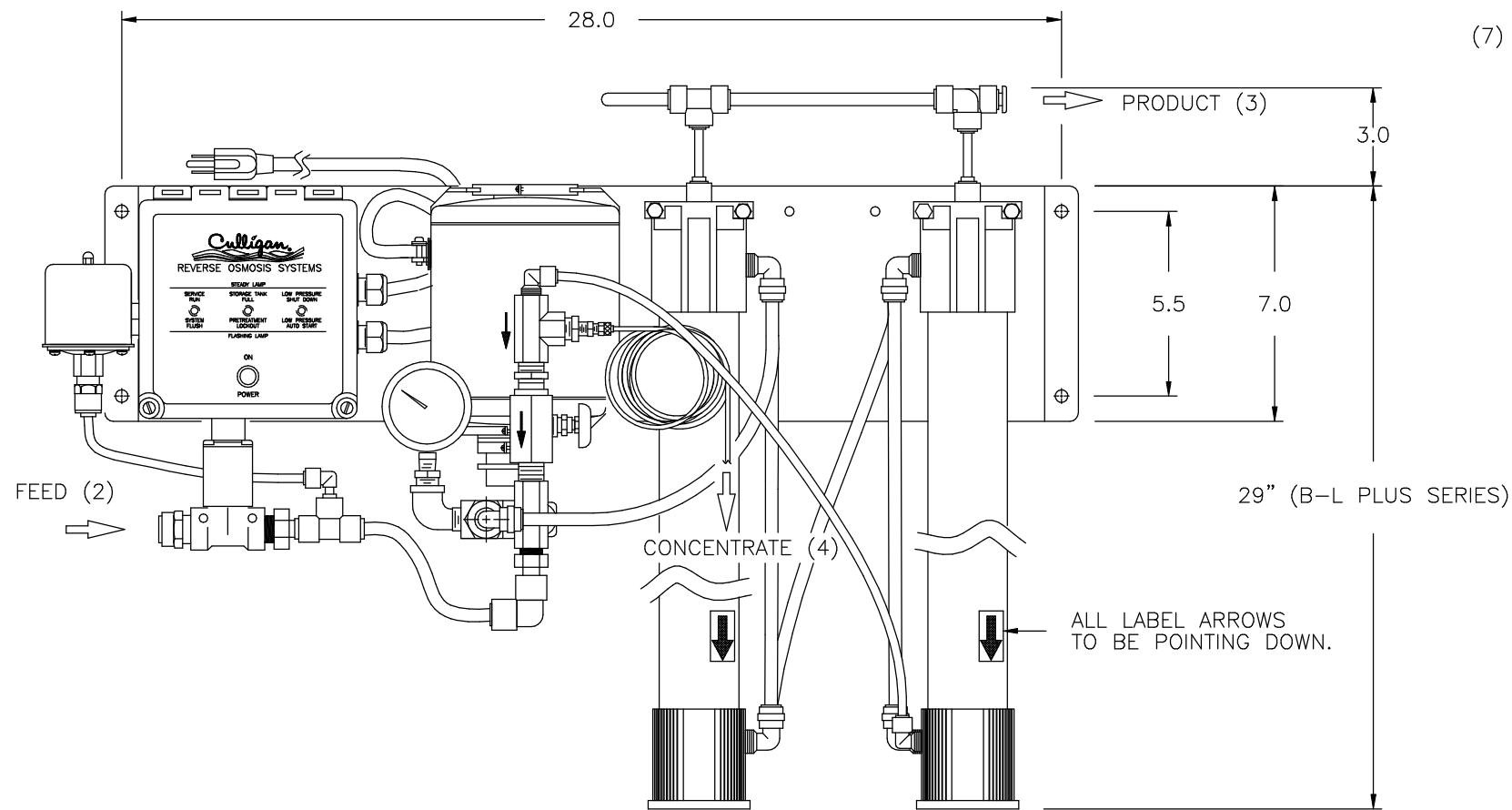

B-4L PLUS SHOWN (FRONT VIEW)

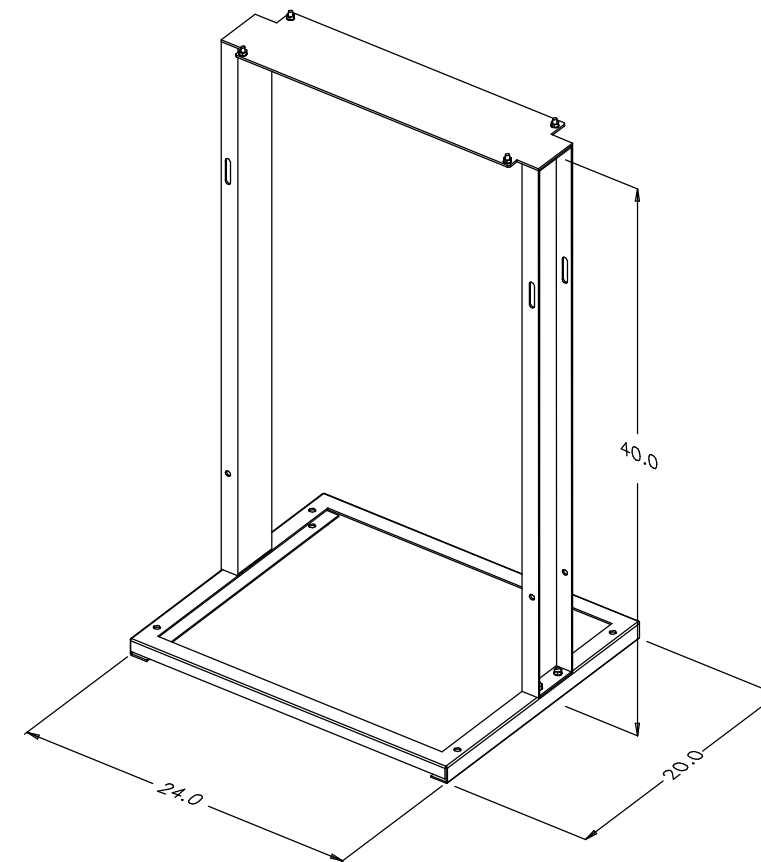

OPTIONAL STAND

DO NOT SCALE DRAWING  
TOLERANCES: ±1/8" UNLESS OTHERWISE NOTED

Let.	Change	By	App	Date

**Culligan®**  
ENGINEERED SYSTEMS  
NORTHBROOK, ILLINOIS

PRINT AND BILL OF MATERIAL ARE NOT TO BE USED WITHOUT THE WRITTEN CONSENT OF CULLIGAN INTERNATIONAL CO.

NAME SERIES B-PLUS REVERSE OSMOSIS UNIT TECHNICAL DATA SHEET		
DETAILED BY: KMR 6/21/04	APP. BY:	SHEET 1 OF 1
REF. NO.	PART NO. RO_B_PLUS	

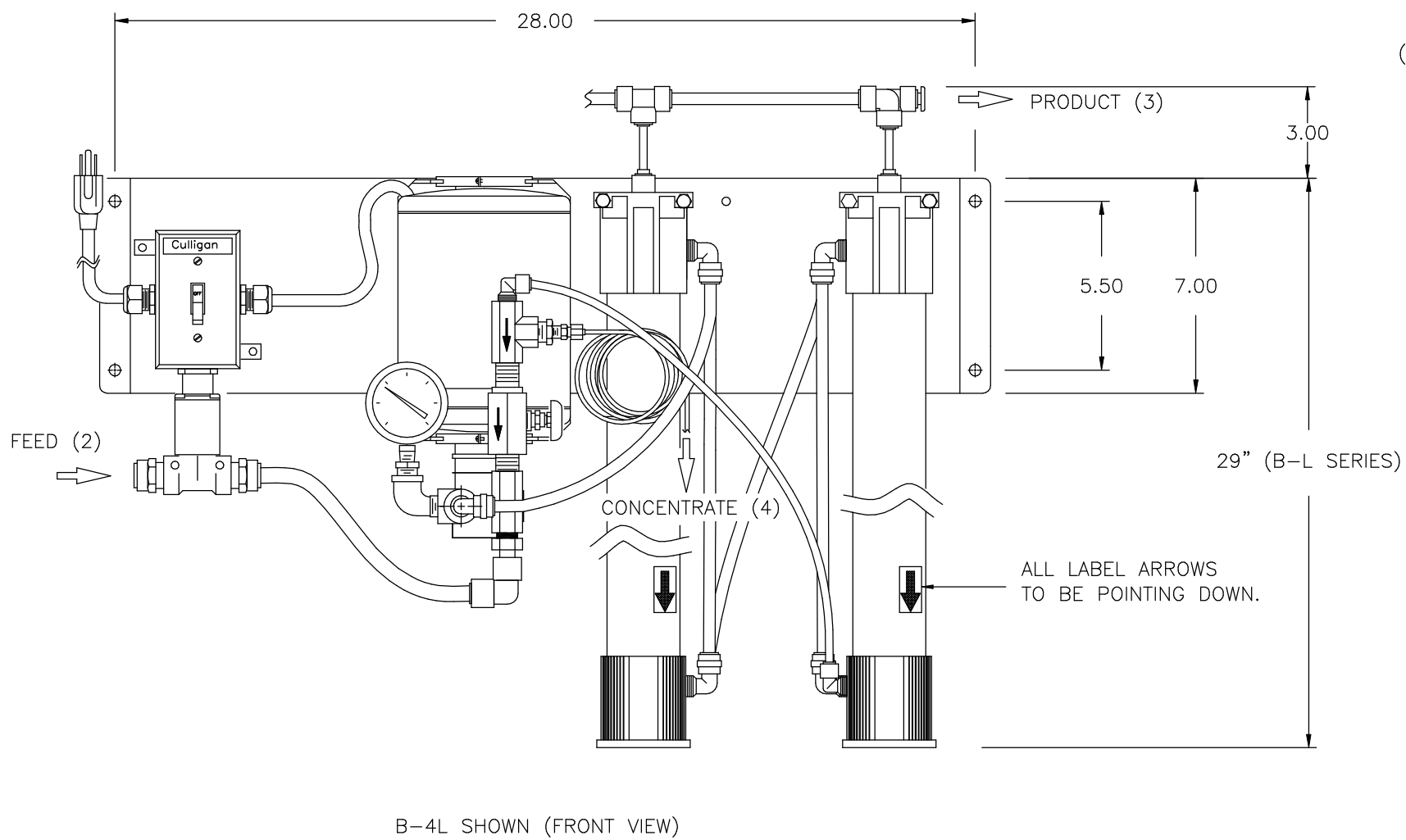
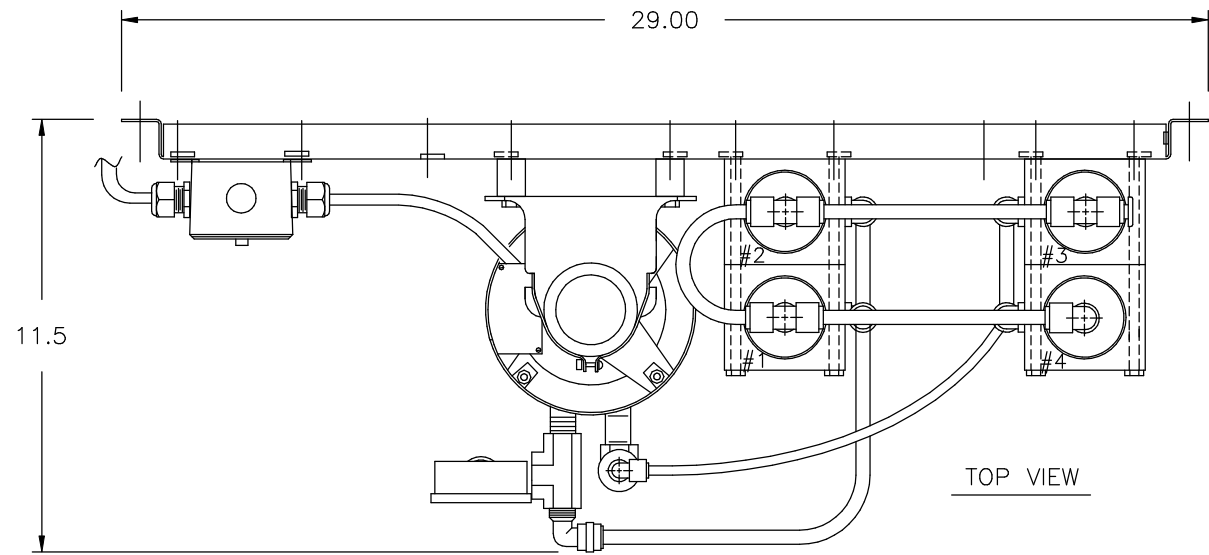

NOTES:

- (1) ALL DIMENSIONS ARE GIVEN IN INCHES AND ARE APPROXIMATE.
- (2) A PREFILTER IS PROVIDED AS PART OF THE UNIT. THE INSTALLER MAY WALL MOUNT THE 4 1/2" DIAMETER X 12" LONG PREFILTER TO ANY CONVENIENT LOCATION. THE PREFILTER HAS 1/2" TUBE CONNECTIONS. PLASTIC 1/2" TUBING CONNECTS THE OUTLET OF THE PREFILTER TO THE FEED WATER INLET OF THE SERIES B UNIT. THE RO INLET WATER CONNECTION IS 1/2" TUBING.
- (3) THE PRODUCT WATER CONNECTION IS 3/8" TUBING.
- (4) THE CONCENTRATE WATER CONNECTION IS 1/8" TUBING (EXCEPT B-4L IS 3/16")
- (5) AN OPTIONAL BRACKET FOR WALL MOUNTING ON 16", 18" OR 20" CENTERS IS AVAILABLE. THE WALL MUST BE CAPABLE OF SUPPORTING AT LEAST 60 POUNDS.
- (6) PROVIDE A DRAIN CAPABLE OF HANDLING AT LEAST 1.1 GALLONS PER MINUTE. DO NOT MAKE A DIRECT CONNECTION TO THE DRAIN. PROVIDE AN AIR GAP OF AT LEAST FOUR TIMES THE DIAMETER OF THE DRAIN PIPE TO CONFORM TO SANITATION CODES AND TO PERMIT THE OBSERVATION OF THE DRAIN FLOW. DO NOT INSTALL A VALVE IN DRAIN LINE.
- (7) THE POWER CORD IS 8 FEET LONG.

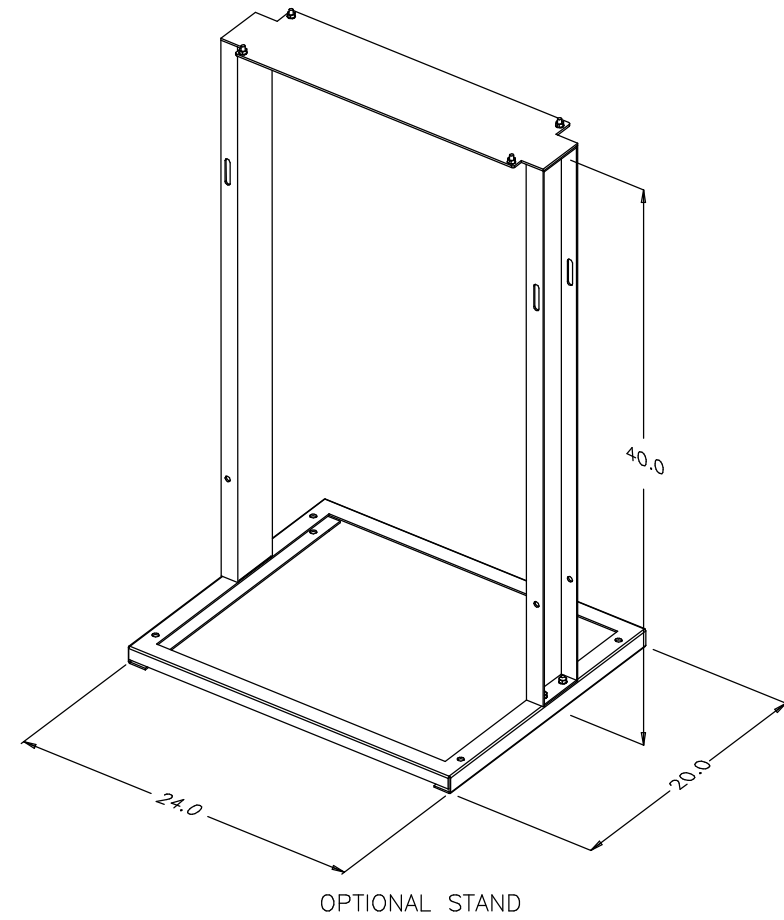

DO NOT SCALE DRAWING TOLERANCES: ±1/8" UNLESS OTHERWISE NOTED					 <b>Culligan</b> <sup>®</sup> ENGINEERED SYSTEMS NORTHBROOK, ILLINOIS PRINT AND BILL OF MATERIAL ARE NOT TO BE USED WITHOUT THE WRITTEN CONSENT OF CULLIGAN INTERNATIONAL CO.	NAME SERIES B REVERSE OSMOSIS UNIT TECHNICAL DATA SHEET		
Let.	Change	By	App	Date		DETAILED BY: KMR 6/21/04	APP. BY:	SHEET 1 OF 1
						REF. NO.	PART NO. RO_B	