

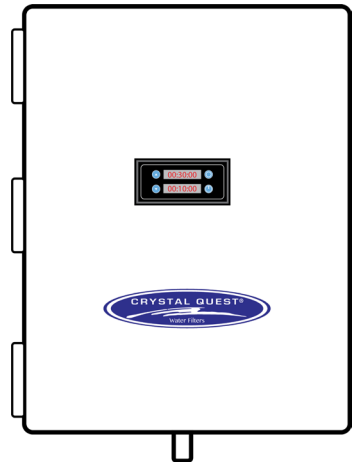

Crystal Quest® Ozonator OZ-400, 600, 800, 2000 INSTALLATION AND OPERATION GUIDE

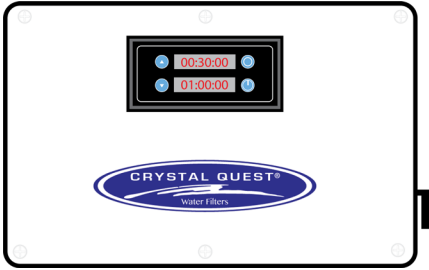

Copyright 2020
Crystal Quest®
All rights reserved
MADE IN THE USA





OZONE SAFETY

What is Ozone?

Ozone (O₃ or trioxxygen) is a blue gas, with a density greater than air, and most importantly it is a powerful anti-viral, anti-microbial, antibacterial, and anti-fungal disinfectant for both air and water. The Crystal Quest Ozone Generator kills single and multi-cellular organisms including bacteria, viruses (very possibly including the COVID-19 coronavirus) and fungi. The infusion time varies depending on the size of the indoor space and the level of ozone that the system produces; after this time you can enjoy a bacteria-free environment with clean air and peace of mind.

Ozone Safety

To guarantee safety during the use of an Ozone Generator, activate the system when the space is unoccupied. The Crystal Quest Ozonator is equipped with a timer to assist with safety and will shut the system down prior to reentry. Please allow at least one hour for the ozone to dissipate before the space is reoccupied.

For Ozone safety, consider what needs to be treated with ozone. Is your goal to sanitize the air you breath, eliminate odors, remove the smell of tobacco, or disinfect contaminated areas?

0.2% of ozone is a significant level; this is why ozone concentration is measured in Parts Per Million (PPM). It only takes 3-4 PPM to kill off all germs, including bacteria, and viruses.

EPA / OSHA STANDARDS:

The Food and Drug Administration (FDA) requires ozone output of indoor medical devices to be no more than 0.05 ppm (parts per million).

The National Institute of Occupational Safety and Health (NIOSH) recommends an upper limit of 0.10 ppm, not to be exceeded at any time.

EPA's National Ambient Air Quality Standard for ozone is a maximum 8-hour average outdoor concentration of 0.08 ppm.

If an ozone air purifier is going to be running while people are present, the EPA recommends the proper settings should be selected so that the ozone level is less than 0.08 ppm.

For best results the ozone generator should be mounted as high in the room as practical. Ozone is heavier than air and it will eventually fall to the floor.

Air circulation is an important factor in how effective ozone works. For large areas, an oscillating fan should be placed next to the generator to help circulate the ozone throughout the room.

Please Remember: Ozone Generators are an electronic appliance containing electrical parts and connections. Your generator will become damaged and the ozone output lessened if immersed in water or operated when humidity is above 60%. Lowering the humidity can often be accomplished with dehumidifier or air-conditioner in the room to be treated.

At high concentrations ozone can cause chest pain, coughing, shortness of breath, and throat irritation. Ozone may also worsen chronic respiratory diseases including asthma and compromise the ability of the body to fight respiratory infections. If the area is occupied with people, pets, and plants during odor elimination and disinfecting, then Ozone machines must be operated with very low settings, in well ventilated spaces, and must follow all EPA guidelines.

None of the information presented here-in is to be construed in any way as medical or legal advice . None of the statements made on this site has been evaluated by any applicable government regulatory agency (Federal or State), nor should the statements or opinions expressed be construed as offering advice of any kind, including but not limited to the diagnosis, treatment, cure or prevention of any disease.



INSTALLATION AND USE

Use a properly-sized ozone generator in short cycles of 1-4 hours at a time. Apply Ozonator treatment incrementally once every two to seven days. The variables for application is TIME and OZONE OUTPUT, so a measured approach is highly recommended if you are not well-versed in the use of ozone. Following the directions and EPA guidelines is the best way to avoid complications.

For Basic Odor Elimination and Disinfection:

1. Determine the designated area for disinfection or shock treatment
2. Place the Crystal Quest Ozonator in an isolated area and plug into a power supply.
3. Set the timer according to the level of disinfection
4. Begin with the top right-hand button to set the first timer which is the pause-time (the time in which the system will not be active)
5. Press the top right button again to set the second timer which is the run-time. This is the amount of time

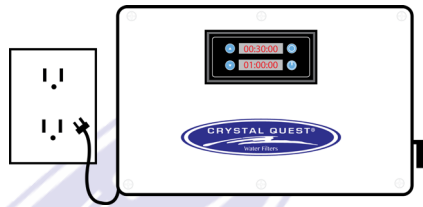

For Shock Treatment / Advanced Odor Elimination and Disinfection

1. Determine the designated area for disinfection or shock treatment
2. Place the Crystal Quest Ozonator in an isolated area and Plug the Ozonator into a power supply
3. Set the run-time for the desired amount of treatment, and do not set the pause-time to allow the system to remain active.
4. Evacuate the area and then close off the area for a few hours to several days, depending on the desired level of treatment.
5. Allow at least double the treatment time for the Ozone to dissipate prior to re-entry.

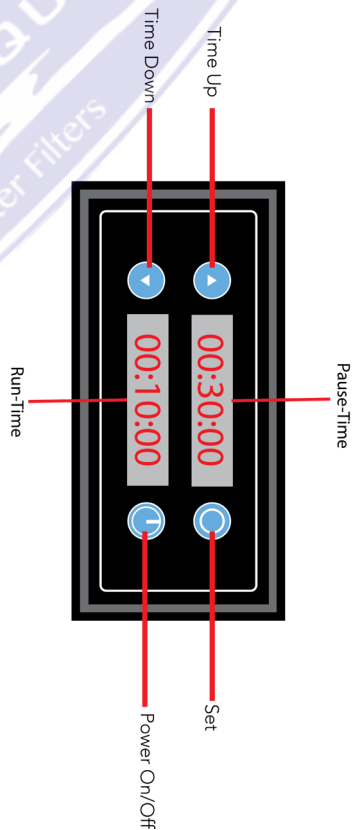



INSTALLATION AND USE CONTINUED...

For decontamination shock treatments .5-2 mg/hr ozone should be used for every 100 sq/ft, depending on the time required to complete the treatment for the specific area and the area's condition. Output of Ozone during decontamination shock treatment will vary upon temperature of the area.

DECONTAMINATION SHOCK TREATMENT IS MOST EFFECTIVE IN 60 DEGREES FAHRENHEIT AND BELOW. GEOGRAPHIC LOCATION CAUSES TEMPERATURES TO VARY (for example an Alaska user vs a Florida user), THEREFORE THE ROOM TEMPERATURE MUST BE SET ACCORDINGLY.

mg/h (milligrams per hour)	Per Square Foot	Treatment Duration
0.5 mg/h - 2.0 mg/h	100	24 - 48 Hours
2.0 mg/h	100	6 - 12 Hours

ONE-YEAR LIMITED WARRANTY

CRYSTAL QUEST® warrants your CRYSTAL QUEST® Ozonator for one year from the date of purchase against all defects in materials and workmanship when used in compliance with the manual. CRYSTAL QUEST® disclaims all implied warranties including, without limitation, warranties of merchantability and fitness for a particular purpose. If for any reason the product proves to be defective within one year from the date of purchase (90 days for filter cartridge), please call for assistance. This warranty gives you specific legal rights and you may have other legal rights which vary from state to state. CRYSTAL QUEST® assumes no responsibility for incidental or consequential damages, for damages arising out of misuse of the product, or the use of any unauthorized attachment. Some states do not allow the exclusion or limitation of implied warranties or incidental or consequential damages; therefore, the above limitations or exclusions may not apply to you. Should service be required during or after the warranty period or should you have any questions regarding how to use your CRYSTAL QUEST® Ozonator, contact our Technical Support Department at service@crystalquest.com, Monday through Friday, 9 A.M. to 5 P.M. Eastern Time.

KEEP THIS MANUAL FOR FUTURE REFERENCE AND UNIT MAINTENANCE

Online warranty information
<http://crystalquest.com/warranty.htm>

Product design is subject to change without notice.

For further assistance, contact your Crystal Quest dealer
or visit us at www.crystalquest.com

To view the latest edition of the OZ-200 Ozonator Guide visit CrystalQuest.com

*Please note all drawings, pictures, colors and sizes are approximate for illustrative purposes only
and may not exactly resemble the end product.*



AUTHORIZED DISTRIBUTOR

Should service be required during or after the warranty period or should you have any questions regarding how to use your devices, please contact manufacturer's Technical Support Department Monday through Friday, 9 AM to 5 PM Eastern Time, or your authorized CRYSTAL QUEST dealer:



Mailing Address:
FilterWater.com
P.O. Box 968
Southampton, PA 18966
USA

<http://www.FilterWater.com>
Tel. +1 (800) 439-0263
Fax +1 (215) 354-0304
Email: Sales@filterwater.com